



BALOO'S BUGLE



Volume 11, Number 3

October Cub Scout Roundtable

November Cub Scout Theme

CUB SCOUT COLLECTORS

Tiger Cub Achievement 5 & Activities

Webelos Craftsman & Scientist

FOCUS

Cub Scout Roundtable Planning Guide

This month boys will be encouraged to show off their collections or to start new ones. Many positive things can be aid for boys having collections. In particular, collecting teaches them to pay careful attention to something, or to study something on their own initiative. **And it's, also, just plain FUN!!!**

CORE VALUES

Cub Scout Roundtable Planning Guide

Some of the purposes of Cub Scouting developed through this month's theme are:

- ✓ **Family Understanding**, Cub Scouts and their family members share memories through their collections.
- ✓ **Personal Achievement**, Boys take pride in their new interests and collections.
- ✓ **Fun and Adventure**, Starting a new hobby is an adventure that can lead to hours of **FUN**

The core value highlighted this month is:

- ✓ **Honesty**, While enjoying and sharing their hobby of collecting, the boys will learn the importance of being trustworthy and loyal.

Can you think of others??? Hint – look in your **Cub Scout Program Helps**. It lists different ones!! All the items on both lists are applicable!! You could probably list all twelve if you thought about it!!

COMMISSIONER'S CORNER

And another Scouting year is off and running. Our Pack's "Join Scouting Night" was successful and since then we have added another 6 boys. The TV Promo on Channel 3 in Philadelphia must be working. My wife and I have temporarily adopted the Tigers. We have never worked with this age before. Our son joined as a Wolf. The greatest part is having all the Adult partners there and seeing them work with their sons. Our first Pack Meeting is coming up and we have 12 boys who earned Summertime Fun awards. A big increase over recent years. Our first Pack Family camping Trip is in early October. It will be a blast. **Get an active program and the boys will find you!!**

My September RT was spirited and everyone is ready to go. We had a blast wearing Circus costumes. Doing magic tricks and singing "The Clowns in the Circus." Speaking of

Roundtables, did you see the article in the October 2004 Scouting about Roundtables?? They certainly chose one of the best around as an example. I have known Ben since he and I took the Roundtable course at Philmont together in 2001. He sure does put on a good show. And will be at our Pow Wow in January. (*See Southern NJ Council in the Pow Wow list*)

I want give a **big Heap How** two Scouters who will be helping me with Baloo's Bugle. You probably have seen their names for the last few months. Commissioner Karl is a Cub RT Commissioner in Ohio and he will be researching and writing the "Special Opportunity" each month. And Commissioner Diane will be writing up the "Training Hint." She, like me, has all grown children but loves Cubbing.

Don't worry - there are lots more opportunities to help put together Baloo's Bugle. Is there a part you would like to do? *Is there a Webelos leader who has great stuff for the Activity Awards?* I really need some help there.

While at Philmont, I met a CM from Buffalo doing Trek 24 with a 726 crew. He was on his second night at Copper Park, I on our first. He used Baloo from time to time in his planning. I hope this is an issue he reads.

According to the Santa Clara County Council Pow Wow book these month's had similar theme's, so you might want to check old Program Helps, Pow Wow Books, issues of Baloo and old Leaders to see what they have for –

September 2000 – Pockets

Talking of Pow Wow Books. It is that time of year again when my books are running out. My Circle Ten, Connecticut Rivers, Utah National Parks and Baltimore Area Council Books all "died" this month. I need new material for this year if I am to keep bringing you quality issues of Baloo. Last year I received many fine Pow Wow books. I can make the same offer again this year – I will trade one of the Pow Wow Book CDs from our Pow Wow for one of yours. Now if you are a regular Baloo reader you probably have noticed that I lean on certain books more than others. The keys to getting your Council's Pow Wow Book into Baloo are – Having it organized either by theme or with a theme section for each month in each chapter (songs, games, cheers, ...). Also, Word or HTML files that I can edit directly helps. When a CD has all Adobe (.pdf) files I must print it then OCR scan it before processing. This becomes very time consuming. Many months I don't have the time to do that or to read through books not organized by

theme looking for theme material. Thank you in advance for your support in helping me to get a lot of new books.

Commissioner Dave

Whittlin' Chip – part III

A concerned leader in NJ

Here is another opinion on cutting the corner of a Whittlin' Chip Card. I have now presented both sides. If there is further discussion, please either (1) Write National (through Scouting Magazine). They are very receptive to letters and have published a few of mine over the years or (2) Join the Cubs-L discussion group on www.usscouts.org and start a thread. Thank you. CD

I think that humiliation is an exaggerated term used today to describe embarrassment. If done properly, the experience with losing a corner of the Whittlin' Chip card will be positive and will help build character one of Scouting's major goals. Time and time again I find that the processes that were once used to help build an understanding of consequences for action are being twisted and terms such as "humiliation" and "harassment" are being used to eliminate the processes. In every case these so called changes to avoid "humiliation" and "harassment" are done based on politically correct notions. Just a reminder - Politically Correct is more times then not, the wrong direction. Unfortunately, more and more people, in our society, are giving in - and morals, values and standards are being lost in the process.

I talked with my son who was a Cub Scout and now a Boy Scout and he said that he'd rather have a corner cut off his card then to lose the privilege altogether. I think that by cutting a corner there is a constant reminder to the Scout that he needs to be mindful of the rules when using his knife. And this will lead to a safer Scout.

PRAYERS AND POEMS FOR SCOUTERS

The Greatest Collection

Cub Scout Roundtable Planning Guide

We give thanks for the greatest collection that is on display tonight at our Roundtable, the collection of beautiful smiles on the faces of all our leaders. We each have wonderful things to smile about, and we all give thanks for that. **Amen**

Lincoln's Thanksgiving Proclamation

Abraham Lincoln, October 3, 1863

From Circle Ten Council's Pow Wow Book

It is the duty of nations, as well as of men, to own their dependence upon the over-ruling power of God; to confess their sins and transgressions in humble sorrow, yet with assured hope that genuine repentance will lead to mercy and pardon; and to recognize the sublime truth, announced in the Holy Scriptures and proven by all history, that those nations are blessed whose God is the Lord. We know that by His divine law,

nations, like individuals, are subjected to punishments and chastisements in this world.

May we not justly fear that the awful calamity of civil war which now desolates the land. May be a punishment inflicted upon us for our presumptuous sins, to the needful end of our national reformation as a whole people.

We have been the recipients of the choicest bounties of heaven; we have been preserved these many years in peace and prosperity; we have grown in numbers, wealth and power as no other nation has ever grown. But, we have forgotten God. We have forgotten the gracious hand which preserved

us in peace and multiplied and enriched and strengthened us, and we

have vainly imagined, in the deceitfulness of our hearts, that all these

blessings were produced by some superior wisdom and virtue of our own.

Intoxicated with unbroken success, we have become too self-sufficient

to feel the necessity of redeeming and preserving grace, too proud

to pray to the God that made us. It has seemed to me fit and proper

that God should be solemnly, reverently and gratefully acknowledged,

as with one heart and one voice, by the whole American people.

I do, therefore, invite my fellow citizens in every part of the United States, and also those who are at sea and those who are

sojourning in foreign lands, to set apart and observe the last Thursday of November as a day of Thanksgiving and praise to

our beneficent Father who dwelleth in the heavens.

Abraham Lincoln, October 3, 1863

The Scouter's Prayer

Connecticut Rivers Council

Dear Lord, from your judgment seat on high,

Look down on a Scouter such as I.

Search me through and find me whole,

Then help me Lord to reach my goal.

Help me Lord to work for Thee,

Guard my homeland - Keep it free

Help me to work with others and be kind,

Helpful with my hands and mind.

Keep me Lord, both well and strong

To help our growing boys along.

Control my thoughts, keep them right, sound, clean weapons for life's fight.

Protect my morals, keep them high,

Grant this to a Scouter such as I.

I really thought this next one was great – How many times have we seen someone anxious to have his son be the first presented with an award cut some corners -

To desire to have things done quickly prevents their being done thoroughly - Confucius

TWC from Troop 151 in Texas made this statement on our Philmont discussion list and it bears repeating for everyone.

The extra knowledge doesn't weigh a thing.

I know I have learned many things that I wondered if I ever would use and any years down the road I was glad I did.

I have seen this come true at many Pack Shows where the Cubmaster thought he was the show, not the boy. -

The minute a man is convinced that he is interesting, he isn't. Steven Leacock

Smiles

*Capitol District
Baltimore Area Council*

Marcia, their RT Commissioner, forwarded this to me and suggested I should recommend we all collect Smiles. I think that is a great idea!!! CD

Smiling is infectious,
You catch it like the flu.
When someone smiled at me today,
I started smiling too.

I passed around the corner,
And someone saw my grin.
When he smiled I realized,
I'd passed it on to him.

I thought about that smile,
Then I realized its worth.
A single smile just like mine,
Could travel the earth.

So, if you feel a smile begin,
Don't leave it undetected.
Let's start an epidemic quick,
And get the world infected!

Human Gadgets

Connecticut Rivers Council

We all have a place in the world it is said
An some are the leaders and some are the led
We all are parts of a great big machine
Where wheels great and small work with pieces unseen
Consider your watch... which part would you choose
As the most necessary bearings, the large cog, the small...
Which one makes it go?? Which part most of all??

Take your car... ..the spring or the screws
The nuts or the Could you do without the wheels, without tires?

The batteries, magneto, the spark plugs, the wires?
If you'd take off the steering wheel, take off the clutch
Or remove all the brakes...would it then be worth much??

No, the greatest fly-wheel could not spin without grease
And it's held in place by one small piece
So don't be dismayed when you seem in a rut
You're important...though you may be only a NUT

TRAINING TIP**Have a New Den Leader??**

Go to Northern NJ Council's Web Site, www.nnjbsa.org/ and click on the Den Leader's Patch. They loaded most of the material from the new "New Den Leader's Kit" onto their site. Plus provided some other useful links. Check it out!!

Monthly Themes &**How do I find what I need to know!**

*Commissioner Diane
Old Hickory Council, NC*

How do we find information for crafts, ceremonies, games, songs, etc to go along with the monthly theme for Cub Scouts? Well, after checking your **Cub Scout Program Helps** and attending your district's **Roundtable**, your number one source should be BALOO'S Bugle, which has everything you need to know and then some for each monthly theme of the year. You can even go back to previous months or years and find additional information to help you plan your meetings with the Cubs, either on a Pack level or a Den level.

I can remember the days when we all traded information at Pow Wow's and Roundtables from our accumulated boxes of years of Cub Scouting (going on 18 years). I still have that box (although my family has wanted to throw it out each time we move), and still use it today, but life is a bit easier with the Internet and various web sites. In that box we would categorize ideas alphabetically by holidays and then the idea itself. For instance, you find a great idea for a craft for Halloween, then start a file labeled "Halloween" and begin to put your ideas for that holiday in that file. Next, you come across some songs or skits that you found at a Pow Wow or Roundtable, so you label a file for "Songs" and one for "Skits" and your file box is beginning to look a bit like mine. This makes life easier when the time comes to find something for our little scouts to do in a productive manner. Keeping a file categorized by theme for a copy of BALOO'S Bugle, keeps these ideas at your finger touch without getting back onto the Internet.

Another place to locate information is **Scouting Magazine**, which is full of ideas for each month of the year. Leaders receive this magazine automatically each month. So don't forget to look through yours for all kinds of good information to help with your planning for the month. I like to keep these issues for future reference, so they are also kept in another resource box.

Craft stores such as Michaels, Ben Franklin, and A.C. Moore have all kinds of craft ideas along with the resources to do them. Some even offer to teach you and/or the Cubs how to do a particular craft. This is great for those male leaders who feel that they are not quite the "Crafty" type. We have had a representative from A.C. Moore come to one of our Roundtables to teach the leaders some craft ideas to use during the holiday season. This benefits the leaders, as well as A.C. Moore as they gave us coupons, and shared information on upcoming craft sales items, as well as craft classes that they offer which in turn gives them new customers. I like to teach the kids how to "Wet", "Stamp", and "Stain" their leather projects. A good resource for this craft is Tandy Leather. You can locate Tandy Leather on the Internet, www.tandy-leather.com if you do not have one nearby. Some Tandy Leather locations are usually good at offering a scouting discount.

Basically, as those of us who have completed that infamous course called **Wood Badge** (always two words) have learned, use your resources! They come in all shapes and

sizes, from training classes taught for Cub Scout Leaders (such as Roundtable, Leader Specific Training, Wood Badge, etc), to books & magazines, the internet, stores, and yes, church (I got a lot of ideas teaching crafts at our retreats for kids).

Is Your Scout Program Designed for Boys . . . or Girls?

Jayhawk Area Council

I found this article posted on the Jayhawk Area Council website. It impressed me and I think you all will benefit from it, too. Having a daughter, I definitely would not characterize her behavior they way they did in the article. But she grew up in a house of Scouts, has been on several Philmont treks and worked staff at Philmont for two summers. Commissioner Dave

Recently, a psychologist who has studied teen suicide and other grossly unacceptable behavior (i.e., school shootings, etc.) observed what we all know intuitively: that boys are far more likely to commit suicide or these other acts than girls. He opined the reason for this is our society largely ignores the unique needs of growing boys and this leads to frustration and a feeling of alienation on their part. When pressed, he characterized "girl" behavior in these words, "sit down, shut-up, be still." Anything else, one would assume, is "boy" behavior.

We need to remember that our Scouts have been sitting in a classroom for six hours before they come to our meeting. Most have an attention span of less than 20 minutes. We cannot expect them to sit quietly and listen to a long lecture on some aspect of Scouting, no matter how worthwhile or well delivered the lecture is. If we attempt to conduct our program counter to the "boy" nature of the Scouts we have in our Troop, we are setting up conditions that will frustrate our boys and give them further proof (in their minds) of how they are unsuitable for the society they will inherit.

If, on the other hand, our meetings are well planned, boy led, with no activity lasting longer than 20 minutes and allow for lots of activity, we will have a program that our boys will look forward to attending and they will invite their friends to join. For ideas on planning a meeting with lots of different activities, check out the resources available in the Scout Shop.

PACK ADMIN HELPS

10 COMMANDMENTS OF DEN CONTROL

Connecticut Rivers Council

1. Regularly use the Cub Scout Ideals: the Motto, the Promise and Law of the Pack, in ceremonies, and as a guide to conduct. You must set the example.
2. Use Den Rules. Start using them immediately. Boys need to know what is expected of them. Make sure both boys and parents know what the rules are.
3. Make uniforms important. Have regular uniform inspections and instill pride in wearing their uniforms. Boys behave differently when they dress up.
4. Be firm, fair and consistent. They will test you from time to time to make sure that you really mean it.
5. Use positive incentives. When the conduct candle burns down or the marble jar is full, give them the special party or outing you promised.

6. Make each boy feel special. Use warm greetings, compliments, words of praise, and fond farewells, liberally for each boy. Make them feel appreciated and wanted.
7. Boys must have input to rules. If you want them to cooperate they should feel that they have some control of how the den operates. You empower them and teach responsibility when they help set the rules.
8. Den programs must be full of short, fun activities. Boys at this age are active and quickly become bored or frustrated. Long talking sessions and complicated craft projects make it difficult to keep control of the meeting.
9. Use lots of help. From time to time, boys require individual attention. They will need help, encouragement, reassurance, advice or just want to tell you something important. You can't give them that attention if your doing it alone.
10. Get to know each boy. Every boy in your den is a unique individual with his own dreams, fears, and sense of humor. He needs to know that you care about him.

Leader Induction Ceremony

Baltimore Area Council

Now that you have recruited new leaders, be sure to induct them properly into their positions. All leaders appreciate recognition even if they insist they don't. It is, also, one of the greatest tools for retention. CD

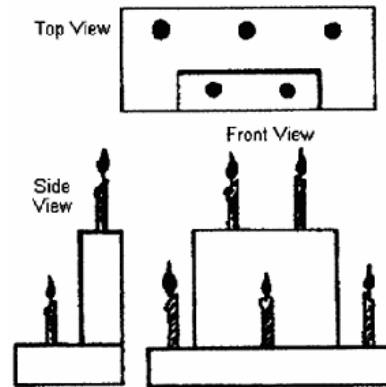

Personnel: Pack Committee Chairman and new leaders.

Equipment: Candles and candle board

Committee Chairman: Before you is a ceremony board that has five candles on it. The top two, like the alert ears of a wolf represent the two upright fingers of the Cub Scout sign. They mean TO OBEY and TO HELP OTHER PEOPLE.

The three candles at the bottom represent the folded three fingers of our Cub Scout sign. These three fingers stand for the three important letters in our law: F-H-G. These letters represent FOLLOWS, HELPS, GIVES. They also mean FAIR. HAPPY and GAME. And finally, they remind us of something each Cub Scout, represents - FREEDOM, HOME, and GOD.

All of our leaders want to do their best to teach Cub Scouts to learn to follow, to help, to give, to be fair and happy whatever the game might be and to respect their freedom, home, and God.

Will the new leaders of our Pack please come forward? (Pause while the new leaders gather at the front of the meeting place.) Please repeat after me:

I, (your name), promise to do my best, to help the Cub Scouts in my Den and in my Pack to do their best, to help other people, and to do their duty to God and their country, and to obey the Law of the Pack.

As chairman of this Pack. I take pleasure in presenting to you your registration cards and personally welcome you into active leadership in Cub Scouting. May the days ahead be: FUN, HAPPY, and GIVING.

TIGERS

REMEMBER –

Tigers now wear the blue Cub Scout uniform with an Orange neckerchief. Youth use Orange tee-shirts as an activity uniform. They are still the Adult Partners uniform.

Achievement 5 Let's Go Outdoors

Baloo Archives

I received a nice e-mail this month from Patricia in the northwest who was concerned that if I did the Tiger achievements in order (A typical thing for this linear thinking engineer to do) I would explain the Outdoor achievement in January. Not a good time for Tigers to spend time outside looking for leaves and hiking. And so here is Achievement 5!! CD

There is so much to do and learn outdoors! You can have fun exploring nature and looking at trees, flowers, and animals. You can walk, run, play games, and ride a bike. It's even fun to sit outside!

Achievement 5F - Family activity

You can listen to a weather report on the radio or television. But it's more fun to tell what the weather is like by going outside and using your five senses to observe what the weather for yourself. Your five senses are seeing, hearing, smelling, tasting, and touching. Some people can't use all five senses fully, such as people who are sight impaired or hearing impaired. Often, people who can't use one of their senses have learned to use their other four senses very well.

5F Go outside and observe the weather. Use your senses to help you describe what the weather is like. What do you see? Is it sunny? Is it dark? Do you see stars, clouds, sunshine, rain, or a rainbow? What do you hear? Do you hear thunder, rain, or the blowing wind? Maybe you hear traffic noise, children playing, or birds singing. How does the weather affect noises like these? What do you smell? Do you smell flowers or freshly cut grass? Maybe you smell the aroma of someone cooking or the odor of farm animals. The air and wind bring these smells to your nose. What do you taste? If the wind is blowing across a dusty place, you may get dust in your mouth. Does the air taste like dirt? Does it taste like salt? What can you feel? Is it cold or warm? Do you feel the wind blowing? Do you feel rain or snow?

The Character Connection on Faith is associated with this Achievement. Don't overlook this important part of the program. Have the Adult partners be sure to carry out the discussion and have the Tiger explain what he knows (This is done by completing the first part of achievement 5F) and

then explain how he feels about things he cannot see (The sun at night, the moon during the day, wind). And finally, in discussing what you believe in but cannot see, what faith is and how you develop faith. Faith is one of Cub

Scouting's 12 Core Values. Don't miss this chance to discuss Faith with your Tiger. For more information on Character Connections check out your Tiger Book, Your Leader's Book or Bill Smith's Unofficial Cub Scout Roundtable at <http://www.wtsmith.com/rt.html> He has the whole BSA publication on Character Connections
Commissioner Dave

Achievement 5D - Den Activity

Many trees and bushes have leaves that turn colors and fall to the ground in autumn. Some trees have needles that stay on all year long. You may live in a place where cacti grow. Cacti have spines or scales instead of leaves. Go outdoors with your adult partner and collect some leaves or needles to take to your den meeting for this activity. Be sure to collect only fallen leavers, or get the permission of an adult before removing a live part of a tree or bush.

And what better time than when the leaves are changing colors to go out and look for leaves and be able to pick them up and compare them. CD

5D With a crayon or colored pencil and a piece of paper, make a leaf rubbing.

Materials: writing paper, leaves, crayons

Place a leaf, vein side up, on a smooth surface, and cover it with a piece of thin writing paper. Hold the paper firmly in position and gently rub the crayon over it. The crayon strokes should all be in the same direction and with just enough pressure to bring out the details of the leaf. The finished design can be displayed in your home, decorated and framed. Your leaf rubbings can also be made into greeting cards or given as a gift.

Achievement 5G - Go and See It

Walking is great exercise, and it's fun to be outdoors. When you walk, you see more things in the outdoors than you would if you went by fast on a bicycle, or in a car or bus.

5G Take a hike.

Your den may go to a special outdoor place for a hike, or you may take a simple walk in your neighborhood. Be sure to take into account the size and ability of your Tiger. There are many state Parks and other parks with short nature trails that have built in rest areas where you stop and read the commentary along the trail (Station 1, station 2,). These may be perfect for your Tigers.

Every Pack should be committed to conduct an outdoor activity within the first three months of the year (September, October, November). My pack has a Fall Family Camping Trip. Our council has a Fall Cub Scout event at one of our camps. Activities like these would be perfect times for your Tigers to get their hikes. CD

Wherever you go, it's fun to be outdoors! Remember, three quarters of Scouting is Outing.

Tiger Theme Related Ideas

- ✓ Elective 16 is Collecting and other Hobbies. This month would be a great time to have your Tigers show off their collections.

- ✓ A museum or zoo visit would be great. You could discuss the collection the museum has. We have a history museum run by the Salem County Historical Society that is perfect for Tigers. It is small, it is local and the volunteer staff is always anxious to help.
- ✓ Be sure to check out the ideas and plans in the Cub Scout Program helps for this month.

SPECIAL OPPORTUNITY

Kommissioner Karl is working a staff at a Wood Badge course but he promised to be back next month with articles on the Cub Scout 75th Anniversary and Outdoor Awards.

In November we have a real special opportunity, a chance to get out and help those who live near us and through the reach of the Scouting program – to help people everywhere. – I am speaking about -

Scouting for Food A National Good Turn

Circle Ten Council

National BSA Good Turns - ORIGIN

The Boy Scouts of America's Good Turn traces back to American businessman William D. Boyce who was lost in a London fog. A boy offered to take Boyce to the address he wanted and refused a tip, saying he was a Boy Scout. Boyce's curiosity was aroused. He later had the boy take him to Scouting's British founder, Lord Baden-Powell. From this chance meeting, the Boy Scouts of America was born.

Among many references to the Good Turn in BSA literature is this comment from the Boy Scout Handbook: "To people who know about Scouting, the daily Good Turn is one of the finest features of our movement. The record of Good Turns, small and large, that have been done by Scouts since the day Scouting was founded is truly impressive."

NATIONAL GOOD TURNS

The following list is compiled from the BSA's historical fact sheet and from Bob Peterson's book *The Boy Scouts, An American Adventure*. There is some inconsistency, and, on many of the earlier Good Turns, there is a certain degree of uncertainty as to whether the event was planned as a national program or just developed that way. In any case, here is a chronological listing.

1912-The first Boy Scout Good Turn promoted a "Safe and Sane Fourth of July."

1917-The day after war was declared on Germany, under the slogan "Every Scout to Feed a Soldier," BSA members were urged to plant vegetable gardens. In two plant-growing seasons, 12,000 Scout farms were established. At the same time, the BSA pledged to aid the American Red Cross and promised cooperation with the U.S. Navy by organizing Scout coastal patrols to watch for enemy ships. The BSA's most significant service during WWI was the sale of Liberty Loan bonds to help finance the war effort. Five bond drives were held, and, in each case, Scouts were called upon to follow up the regular canvas by adult volunteer salesmen. They sold a total of 2,238,308 bonds worth either \$147,876,902 or \$355,000,000, depending on the information source. Scouts also sold war savings stamps to a

value of either \$3 million or \$53 million, again depending on the source. During WWI Boy Scouts collected peach pits and nut hulls which were burned to make charcoal for gas mask filters. More than 100 train carloads were gathered. Another WWI Good Turn involved a national census of standing black walnut trees. Its wood was prized for gunstocks and airplane propellers. The BSA located 21 million board feet, or enough to fill 5,200 railroad cars. Scouts served as dispatch bearers for government agencies and delivered 30 million (or 300 million, depending on source) pamphlets during WWI. Scouts also aided the American Red Cross and the United War Work Committee.

1934-President Roosevelt called on Boy Scouts to collect household furnishings, clothing, and other items to help the needy during the Depression. More than 1.8 million articles were collected. During WWII the BSA responded to 69 requests for help from the government. These requests included: 1941-Scouts distributed 1.6 million defense bonds and stamp posters; began the collection of aluminum and waste paper; conducted defense housing surveys; planted victory gardens; distributed air-raid posters; cooperated with the American Red Cross; and, by agreement with the Office of Civil Defense Mobilization, formed an Emergency Service Corps composed of older Scouts who served in three capacities: messengers, emergency medical unit assistants, and fire watchers.

1942-Scout projects included: delivery of millions of war-bond pledge cards-it was estimated they were indirectly responsible for sales of \$1.8 million worth of bonds and stamps; collection of a vast amount of rubber, primarily old tires, estimated at either 5,898 tons or 30 million pounds; and continuation of scrap and paper drives. During the first drive, Scouts collected 5,000 tons of aluminum; other sources added another 17,400 tons of tin cans and 20,800 tons of scrap metals.

1944-Boy Scouts were sent to collect milkweed floss as a substitute for the kapok used in life jackets-total collection was 750 tons. An estimated 184,000 victory gardens were planted by Scouts. An estimated 126,000 Boy Scouts helped farmers with their harvests. The largest single war-effort project conducted by the BSA was the 1945 General Dwight D. Eisenhower Waste Paper Campaign. More than 700,000 Boy Scouts and Cub Scouts gathered 318,000 tons of paper; this brought the total paper collected during WWII to more than 590,000 tons. Scouts collected 10 million used books for military personnel.

Scouts collected 7,000 tons of used clothing that was distributed to refugees in Europe and China.

1950-51-Two million pounds of clothing for overseas relief was collected at the request of the American Council of Voluntary Agencies for Foreign Service and the United Nations.

1952-More than 1 million boys went house-to-house and placed 30 million Liberty Bell doorknob hangers and a million posters (in businesses) to remind citizens to vote in the presidential election. Scouts also cooperated nationally in securing blood donor pledges, collected clothing for

worthy causes, distributed seeds for Asia, and aided in conservation projects and civil defense.

1954-A National Conservation Good Turn involved the distribution of 3.6 million copies of a conservation poster. In parks, rural areas, and wilderness areas, Scouts planted 6.2 million trees; built and placed 55,000 bird-nesting boxes; and arranged 41,000 conservation displays.

1956-The second national get-out-the-vote campaign was launched with 36 million doorknob hangers and 1.4 million posters distributed.

1958-National Safety Good Turns were conducted. The BSA delivered 40 million emergency handbooks prepared by the Office of Civil Defense Mobilization. Also, 50,000 posters were placed in post offices.

1960-The third national get-out-the-vote campaign was conducted.

1970-Project SOAR (Save Our American Resources) was initiated as an ongoing BSA project. It's estimated that during the year, 60,000 BSA units took part in SOAR-related conservation projects.

1980-Scouts distributed fliers urging support of the national census.

1986-An estimated 600,000 youth members distributed 14 million brochures to families informing them of the need for donated human organs and tissue and urging them to make a commitment to donate. Millions of other homes were reached through publicity and other promotional efforts.

1988-The first Scouting for Food collection was completed. One million Scouts collected an estimated 65 million cans of nonperishable food.

1989-1991-The continuing Scouting for Food collection resulted in a combined total of an additional 209 million cans of food for people in need.

2000 - the Boy Scouts of America committed itself to donating 200 million hours of community service as part of its support for "America's Promise" campaign.

What is Scouting for Food?

A Cub Scout promises to "give good will" and a Boy Scout promises "to help other people at all times." What better way is there to show our Scouting Spirit than by participating in the annual Scouting for Food drive?

Over the years, the Local Councils of the Boy Scouts of America have worked diligently to improve our communities and the welfare of the families who reside in these communities. One very special project begun recently has grown to be extremely important to many agencies, families and individuals. This "Good Turn" Event is known as the **Scouting for Food Campaign**.

The mission of the project is to have all Scouts participate in the collection of food items to be given to needy people and families within the communities of the council. The goal is to have 100% participation from all units in this most important community outreach program. Cub Scout Packs, Boy Scout Troops, Varsity Teams, and Venturing Crews do make a difference when they support and participating in this annual Good Turn.

In my area, Channel 6 WPVI, the local ABC affiliate has sponsored this drive and helps with publicity, placing food collection containers in stores and other stuff. The publicity helps the spread the word and increase participation. Commissioner Dave

How can you help?

You can distribute and then collect the bags of food left on the porches and steps, from around your neighborhood.

Man collection sites

Help unload food drive items at the Network of Ministries, Salvation Army sites or Food Bank locations.

CONTACT your council or district Food Drive chairmen for more details and a listing of assignments available.

**Boys' Life Reading Contest
Enter the 17th Boys' Life Reading Contest Now!**



Write a one-page report titled "The Best Book I Read This Year" and enter it in the *Boys' Life* 2004 "Say Yes to Reading!" contest.

The book can be fiction or nonfiction. But the report has to be in your own words—500 words tops. Enter in one of these three age categories: 8 years old and younger, 9 and 10 years old, or 11 years and older.

First-place winners in each age category will receive a \$100 gift certificate good for any product in the Boy Scouts Official Retail Catalog. Second-place will receive a \$75 gift certificate, and third-place a \$50 certificate.

Everyone who enters will get a free patch like the round one above. (The patch is a temporary insignia, so it can be worn on a Cub or Boy Scout uniform shirt. Proudly display it there or anywhere!) In coming years, you'll have the opportunity to earn the other patches.

The contest is open to all *Boys' Life* readers. Be sure to include your name, address, age and grade on the entry.

Send your report, along with a business-size, self-addressed, stamped envelope, to:

Boys' Life Reading Contest, S306
P.O. Box 152079
Irving, TX 75015-2079

For more details go to www.boyslife.org

Entries must be postmarked by Dec. 31, 2004.

GATHERING ACTIVITIES

A Yummy Puzzler

Southern NJ Council

Have a collection of candy wrappers (or the real thing) and have people figure out what wrapper goes with which answer.

1. Greasy digits _____
2. A baseball player _____
3. A sarcastic laugh _____
4. One of Charlie Brown's girlfriends _____
5. A long run _____
6. A planet _____
7. Overweight _____
8. An author _____
9. A big mass of stars _____
10. What a worker looks forward to _____
11. Small Hills _____
12. The number before one _____
13. A famous trio of men _____
14. Definition of an object you can't identify _____
15. Mountain tops _____
16. The terminology of a body builder _____
17. The elite street in New York _____
18. A large sum of money _____
19. Pooh's favorite _____
20. A little laugh _____
21. A lazy cow _____
22. Feline nickname _____
23. Opposite of bad and few _____
24. Tumbling girl _____
25. Lazy Cowboy _____
26. African monkey parts _____

A Yummy Puzzler Answers

- | | | |
|---------------------|---------------------|------------------|
| 1. Butterfinger | 2. Baby Ruth | 3. Snicker |
| 4. Peppermint Patty | 5. Marathon | 6 Mars |
| 7. Chunky | 8. O'Henry | 9. Milky Way |
| 10. Pay Day | 11. Mounds | 12. Zero |
| 13. 3 Musketeers | 14. Whatchamacallit | 15. Snow Cap |
| 16. Crunch | 17. Fifth Avenue | 18. 100 Grand |
| 19. Bit-O-Honey | 20. Chuckles | 21. Milk Duds |
| 22. Kit Kat | 23. Good 'n Plenty | 24. Tootsie Roll |
| 25. Slowpoke | 26. Reese's Pieces | |

What in your pockets?

Connecticut Rivers Council

As the cub scouts arrive have them take everything out of their pockets and put them in a brown paper lunch sack. Have them write their name on it. And then have them leave it on the table. After a few people have arrived give each boy a piece of paper with the cub scouts names printed on them. Now have each boy take a guess at what each boy has in his sack and write it by that boys name. After everyone has played, have each boy open his sack and show everybody what: was in his pocket. This is also a great audience participation... get to know you game.

Spell Pocket

Denver Area Council

Where else would a Cub begin his collection but in his pocket!!! On a sheet of paper, spell out the word 'pocket'. Using these letters, have everyone list items that you find in a boy's pocket.

For Example:

P: paper, ping pong balls, pencils, etc.

O: old candy papers, odd buttons, etc.

C: candy, cards, etc.

K: keys, kite string, etc.

E: envelopes, egg, etc.

T: trucks, tinker toys, etc.

Clothespin Mixer

Northwest Suburban Council

Equipment: Clip-on clothespins - 3 or 4 for each person

The object here is to **not** get a collection. Give everyone 3 or 4 clothespins. Tell them that the object of the game is to get rid of their clothespins without having anyone else pin THEIR clothespins on them. With everybody trying to get rid of his or her clothespins at the same time, as fast as possible, this is a rowdy and fun way to start a meeting.

WHO COLLECTS WHAT

Southern NJ Council

- | | | |
|-----------------------|----|----------------|
| 1. ROCK HOUND | A. | STAMPS |
| 2. FOLK SINGER | B. | RECIPES |
| 3. NUMISMATIST | C. | TIMETABLES |
| 4. HAM RADIO OPERATOR | D. | COINS |
| 5. COOK | E. | OLD FURNITURE |
| 6. LEXICOGRAPHER | F. | CALL NUMBERS |
| 7. PHILATELIST | G. | FIRST EDITIONS |
| 8. ANTIQUE COLLECTOR | H. | BALLADS |
| 9. RAILROAD BUFF | I. | OBSIDIAN |
| 10. BOOK LOVER | J. | WORDS |

Answers:

1-I, 2-H, 3-D, 4-F,5-B, 6-I, 7-A, 8-E, 9-C 10-G

OPENING CEREMONIES

What Do Boys Collect?

Trapper Trails

Preparation: You will need each boy to have one of the following in his pockets: a frog (plastic, unless you are brave), dirt, marbles, rocks, and a small flag. Have boys practice their parts ahead of time.

Cubmaster: Have you ever wondered what boys collect and why? Let's see what we can find out tonight.

- Cub # 1:** (pulls out frog): This frog reminds me of freedom of speech, he can croak all he wants and no one stops him.
- Cub # 2:** (pulls out dirt): This dirt reminds me of our forefathers as they put their feet on American soil for the first time.
- Cub # 3:** (pulls out marbles): These marbles remind me of the pilgrims as they worked and played in this new land of freedom.
- Cub # 4:** (pulls out small flag): This flag stands for our country will you please join me in the Pledge of Allegiance?

Collections

Heart of America Council

Personnel: 11 Cubs and Den Leader or Den Chief.
Equipment: Cards with letters spelling out **C O L L E C T I O N S** with the text written on the back in **LARGE** print

- Narrator:** We would like to tell you what we collect from Scouting.
- Cub # 1:** **C:** is for Courtesy. A Scout learns to do good deeds and respect others.
 - Cub # 2:** **O:** is for Outing. Outing is one of the most fun parts of Scouting. Camping and hiking, we always look forward to our time outdoors.
 - Cub # 3:** **L:** is for Learning. A Scout learns many things, first aid, knots, physical skills, citizenship and sportsmanship.
 - Cub # 4:** **L:** is for Leaders. One of the most important parts of the Scouting organization.
 - Cub # 5:** **E:** is for Exploring. A Scout learns the skills he needs to explore the outdoors.
 - Cub # 6:** **C:** is for Challenges. A Scout is presented with many challenges and is helped to meet them and to succeed.
 - Cub # 7:** **T:** is for Try. A Scout learns to always try to do his best.
 - Cub # 8:** **I:** is for Identify. A Scout learns to identify different kinds of leaves, trees and tracks.
 - Cub # 9:** **O:** is for Observe. A Scout observes the Outdoor Code whenever he goes camping or hiking.
 - Cub # 10:** **N:** is for Nationalism. Every Scout around the world is a patriot to his country.
 - Cub # 11:** **S:** is for Scouting. We are very glad Baden-Powell had the vision to bring this program into being.

Narrator: *Narrator or another Cub or Den Leader now leads Cub Scout Promise, law of the Pack and / or Pledge of Allegiance*

I Made A Promise

Denver Area Council

- Cub # 1:** I made a promise. I said that whatever I did, I would do the best I could.
- Cub # 2:** I made a promise to serve my God and my country the best I could.
- Cub # 3:** I made a promise to help other people the best I could.
- Cub # 4:** I made a promise to obey the Law of the Pack the best I could.

- Cub # 5:** I have done my best. I will do my best, because I am the best, I am a Cub Scout.
- Den Ldr:** Will everyone now join us in repeating the Cub Scout Promise.

Opening Ceremony

Baltimore Area Council

- Equipment:** Boys come out with props to match their hobbies.
- Cubmaster:** This month's theme is Cub Scout collectors and Den ____ is going to help open the meeting by showing some people's favorite past-times.
- Cub # 1:** I'm always making something new, It gives me something fun to do. Perhaps I'll make a box of wishes, But first I have to wash the dishes.
 - Cub # 2:** I like to play my favorite song, Sometimes the family sings along. I might become a music star, but first I have to wash the car.
 - Cub # 3:** I sail my ship out to the sea, A sailor's life's the life for me. To sail around the world's my dream, But after work I've lost my steam.
 - Cub # 4:** I like to golf and be outside, in my golfing cart I ride. A pro golf tour could be my fame, But housework comes before the game.
 - Cub # 5:** Video games are the best, I play better than all the rest. I could invent an awesome one, But to the school bus I must run.
- Cubmaster:** Thank you Den _____. Everyone take to have fun with their hobbies and collections, but as you can see, you have to do some work before you can play. Let's see how much work the Cub Scouts did this month and see how many advanced, but first we will begin with the Pledge of Allegiance.

History of Our Country's Flag

Baltimore Area Council

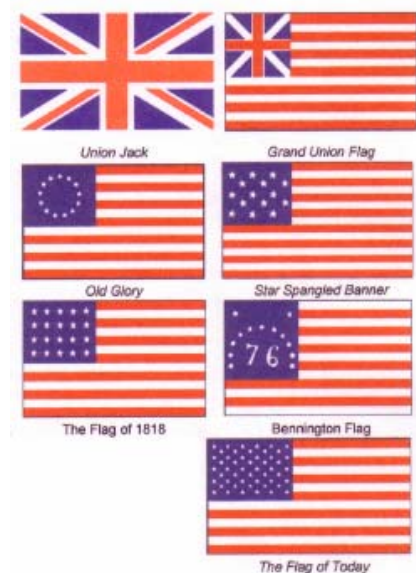

Preparation: Each Cub should have a picture of his flag with the words in large print on the back. Even better would be to have a set of historical flags to show. Don't be afraid to change the flags talked about. If you have a 48 star flag,

"Old Glory" that flew over the US during the two world wars or a "Don't Tread on Me" flag, use it. Write your own parts.

Cub # 1: One of the greatest collections is the collection of flags that have flown over our country. Let's listen to our Cubs as they tell us about a few of these American Flags.

Cub # 2: This is the British Union Flag or Union Jack. It flew over the British Colonies in North America from the landing of the first Colonists at Jamestown in 1607 and at Plymouth in 1620 until the Revolution.

Cub # 3: This is the Grand Union Flag. At the beginning of the American Revolution, the colonists hoped not so much to gain independence as to correct the wrongs done them under the rule of George III. They kept the British Jack out of loyalty to the crown, but added the 13 stripes to show their own unity. It was raised the first day of January, 1776, over George Washington's headquarters.

Cub # 4: This is Old Glory, the first official flag of the United States of America. It was created by a resolution of the Continental Congress, passed June 14, 1777 - a date we celebrate as Flag Day.

Cub # 5: This is the Star Spangled Banner. When two more states joined the original 13, stars and stripes were increased to 15. This flag of 15 Stars and Stripes flew over Fort McHenry the night of its bombardment in 1814, and inspired Francis Scott Key to write the verses of our National Anthem.

Cub # 6: This is the flag of 1818. As more states joined the Union, the flag would become an awkward shape if more stripes were added. Therefore, on April 4, 1818, Congress passed a law that restored the design of the flag to 13 stripes and provided that a star should be added for each new state.

Cub # 7: The Bennington Flag is of an unusual design. Although it has 13 stripes, the top and bottom stripes are white instead of red. The 13 stars have 6 points. They are arranged to form a Gothic arch over the '76' which commemorates the year American independence was proclaimed.

Cub # 8: This is the flag of the USA today. The 13 stripes remind us of the original colonies. The 50 stars represent the states that bound together into one country. Please stand and join us in the Pledge of Allegiance to Old Glory.

Opening - Who Collects What?

Baltimore Area Council

Equipment: This can be as simple or as elaborate as you like. The boys can wear signs around their necks showing their hobbies, or they can dress the part, with as many or as few props as you like. If you don't have enough boys, let them double up on Cub Scouts 1 through 10. In any case, the last Cub Scout (Cub #11) should be in full uniform.

Cub # 1: I am a rock hound. I collect obsidian, quartz, and other minerals.

Cub # 2: I am a folk singer. I collect ballads to perform and share.

Cub # 3: I am a numismatist. I collect coins.

Cub # 4: I am a ham radio operator. I collect post cards with the call numbers of other radio operators..

Cub # 5: I am a cook. I collect recipes

Cub # 6: I am a lexicographer. I collect words and famous historical autographs.

Cub # 7: I am a philatelist. I collect stamps

Cub # 8: I am an antique collector. I collect old furniture

Cub # 9: I am a railroad buff. I collect railroad timetables and other railroad memorabilia.

Cub # 10: I am a book lover. I collect first editions

Cub # 11: I am a Cub Scout. I collect a lot of the things already named for my achievements and electives. I also collect rank badges and arrow points as I learn and grow. I've also collected the knowledge about how to be a good citizen. Please stand and join me in the Pledge of Allegiance.

Collectors Opening

Connecticut Rivers Council

Ten cub scouts come on stage holding cardboard signs shaped like pockets or collector's boxes. Write each spoken part in BIG letters on the back of each letter, so that the boys can read it. ***Be sure to add an introduction and a Pledge of Allegiance***

Cub # 1: C - Coins and stamps and rocks galore,

Cub # 2: O - Old bottle caps and pieces of string,

Cub # 3: L - Lizards and lights and lucky rabbit's feet

Cub # 4: L - Love letters and lollipops and other things,

Cub # 5: E - Every boy likes to collect this stuff;

Cub # 6: C - Capes and cats and magic hats

Cub # 7: T - Toads and toys and more items to count

Cub # 8: O - Old cars and shells and silly mats

Cub # 9: R - robots and rough riders and all the jazz

Cub # 10: S - So join with us as we reflect on all the wonderful things we collect

PACK AND DEN ACTIVITIES

Collections

Southern NJ Council

So why not have the boys begin developing some collections of their own? Hey, how about stamps? Ever consider taking a field trip to your local Post Office and see what they have to offer? How about everyday collectibles, like rocks, leaves, insects, etc? You can get someone who collects things to come in and talk to the boys about what to collect and how.

All kinds of collections can be found in boys pockets! Collecting is a very big part of every boy's life;

- Sport Cards
- Coins
- Rocks
- Arrowheads
- Star Wars items
- Autographs
- Patches
- TV or Movie posters
- Stamps

The list could go on and on. The Cub Scout program encourages collecting. You could take your den on field trips to special places too obtain information about collecting.

- Rock quarry: Rocks, gems, and minerals
- Butterfly Pavilion: Insects, butterflies
- Sports groups: Sports cards
- Scout Service Center: Patches
- Post Office: Stamps
- Federal Mint: Coins

Other ideas for collecting: Take a hike with a purpose. If you can't collect the actual items,, then bring along a camera to take pictures of the items. The pictures could be labeled and put inside an album.

- Check your Boy's Life Magazine - There are lots of suggestions for collections.
- Internet - surf he net for suggestions on collections.
- Collector's exhibits - family members - check out your attic or basement.
- Have fun with collections - you never know when it might turn into a lifelong hobby or occupation.

Show-n-Tell

Southern NJ Council

Yeah, I know. It sounds like something for a group of kindergartners. But really, this works too. We've talked before about how difficult it is for people to speak in front of others so you know this helps them warm to the idea. And, believe it or not, this is also a fun thing to do. (I know, because I sat through just the same thing when my son was in Cub Scouts. The boys really enjoyed doing it and the parents and families that "came out to the program" thought it was really neat too. And as I recall, the parents had to bring in and talk about their collections, too.

PACK FAMILY HOBBY DISPLAY

Southern NJ Council

Have a family hobby corner at the pack meeting. Ask each family to bring a sample of what they collect as a family or things that represent their hobby. Families who like baseball can bring baseball equipment, uniform, baseball cards, photos and maybe some trophies. Families who like movies can bring movie posters and movie paraphernalia including popcorn! Families who collect seashells can bring some in a box. It doesn't have to be a "formal" hobby - it's something a family does together. How about a family who buys T-shirts where they go? Set a time during the meeting for families too go around and admire each other's hobby. Family members can take turns staying at the "booth" to explain about the hobby

Rock Paperweights

Southern NJ Council

Rocks are fun to collect, and these delightful creations are fun to give. Look for the best rocks that you can find, smooth, interestingly textured, shaped or colored, and get some glue paint, twine, eyes and other decorative materials. Clean the rocks well. Choose a large rock for the basic body. Then either paint a face, picture or design on this rock and varnish, or choose smaller rocks to glue on as legs, head,

eyes and ears. Paint and varnish. Pieces of yarn or string can be glued on for hair or tails.



Tuna Can Bug Collecting Box
Baltimore Area Council

Materials: Two clean tuna cans with labels removed and preferably opened with a top opening as opposed to a side opening can opener (top opening can openers leave no sharp edges), 6 x 11" piece of wire screen, red marker. Optional: spray paint and markers.

Instructions:

Option: you can spray paint & then decorate the tuna cans with the markers if you so desire.

1. Pull two wire strands from one of the 6" sides of the screen.
2. Roll the screen to make a 6" tube with a diameter smaller than the inside of the tuna cans and the end that you pulled the strands from on the outside.
3. Slip a tuna can over each end of the tube. Release the screen so that the tube expands to fit snugly inside the tuna cans.
4. Being careful to hold the screen together, remove one of the tuna cans. Thread the wires that you exposed when you pulled the strands into the holes in the section of screen rolled to the inside. Now fold them back on themselves to hold the tube together. Continue down the tube until you reach the other tuna can. Remove the second tuna can and finish threading and folding until the tube is complete.
5. Slip both cans back on and you have a bug box to collect all the little creepy crawlies you want.



COLLECTING POSTMARKS
Southern NJ Council

This will get the boys started with the Wolf achievement or Bear arrow on collections. Ask each boy too bring a self-addressed, stamped Christmas card to the meeting. Put all

their cards into a large envelope, and write "Postmark Request" in the lower corner.

Mail the envelope to Postmaster, C/O the town listed below. Your letters will then be mailed from that town and the boys will have "Christmas" postmarks for their collection.

Bethlehem, GA 30620	Mistletoe, KY 41351
Noel, MO 64854	Rudolph, WI 54475
Silver Bell, AZ 85270	Christmas, FL 32709
Nazareth,, PA 18064	North Pole, AK 99706
Santa Claus, IN 47579	Wiseman, AR 72587

Display stamps in a book or case so that you and others can enjoy the stamps with damaging them.

COLLECTING COINS

Southern NJ Council

There are many places too find coins to start or add to your collection. Coin shops are obvious places too begin the search. Then there are coin shows, which offer plenty of choices, and often some very good bargains. No matter where you are in your collection, joining a coin collecting society can be a benefit. You'll met fellow collectors,, trade with them, learn the ins and outs of the marketplace, and be less likely to take any wooden nickels And you might make a friends, too. Coin folders are a great way to organize, catalog and display your coin collection.

ALONG THE SHORE

Southern NJ Council

There are so many pretty things to be seen along the shore - so many things that can add to a boy's knowledge - pretty stones and shells, beautiful flowers and funny bugs, turtles and frogs,, snakes and cattails, seed pods and birds. The study and collection of shells is called conchology. Tiny shells can be kept in small bottles with screw caps or corks. Medium shells may fit into matchboxes. Larger shells can be kept in cardboard boxes. Shells can be mounted on cardboard with household cement. Each shell should be identified and labeled. For a special display,, glue shells too golf tees with household cement. Then press the points of the tees into a piece of Styrofoam.

LEAVES AND SEEDS

Southern NJ Council

Collecting the leaves and seeds from trees helps the Cub Scout too learn to recognize many different trees. Seeds can be stored in glass pill bottles, plastic coin tubes, square and rectangular plastic boxes. For larger seeds such as walnuts, acorns, pecans, Brazil nuts and peanuts, use plastic or cardboard egg cartons. The best way to catalog seeds is to label each jar or box with the name. Self-sticking labels work well. Cardboard tags with strings can be used for labeling pine cones or similar large items. To display the collection, the seed bottles or vials can be wired to heavy cardboard or a piece of plywood.

ROCKS AND MINERALS

Southern NJ Council

Good places to find rock specimens is in roadbeds,, riverbeds, roads under construction, and building excavations. Choose rock and mineral specimens carefully.

Don't pick up just anything. Wrap each in a piece of newspaper with a card to show where you found it. Rocks can be chiseled to standard size (such as 2 by 3 inches) with a geologist's hammer or a regular hammer and a cold chisel. (Be sure to wear protective glasses when chiseling).

Label rocks by attaching a small label too the underside with transparent tape or by painting a small white spot, on which you can write the identification. Show the types of rock, where it was found, and the date. Small rocks can be kept in pill bottles. Larger rocks may be kept in sectioned boxes or egg cartons.

SHIRT POCKET PUPPETS

Connecticut Rivers Council

Puppets made from shirt pockets may be made by cutting the pocket portion from an old shirt, leaving about 2" of the shirt attached all around the pocket. This extra material can be fringed for hair, beards, lions I manes, etc. Slip the pockets onto your hands so you can determine where to cut "armholes" for your thumb and forefinger. Make faces with crayons.

Funny Putty

Connecticut Rivers Council

Materials needed for each boy:

- 1 tablespoon liquid starch,
 - food coloring,
 - 2 tablespoons white glue,
 - a plastic egg or small zip-lock bag.
1. Mix glue and food coloring together in small bowl.
 2. Pour liquid starch into a second bowl,
 3. then slowly pour the glue mixture on top of the starch.
 4. Allow the concoction to stand for 5 minutes or until the glue absorbs the starch.
 5. Remove putty from bowl and knead. (At first, the mixture looks as if it's a mistake, but it isn't. The more you knead the putty, the better the consistency will be.)
 6. Store Funny Putty in egg or zip-lock bag.
- Press Funny Putty down on newspaper comics or pictures printed on inkjet paper. Slowly pull the Funny Putty off of the paper. The picture will transfer BACKWARDS onto the putty. You can also roll your funny putty into a ball and bounce it.

Washable Finger Paint

Connecticut Rivers Council

In large saucepan mix 1 cup all purpose flour with 1 cup cold water. Stir until smooth. Then add another 3 cups cold water. Cook over medium heat, stirring till mixture thickens and bubbles. Reduce heat and simmer 1 minute more while still stirring. Divide into three heat-resistant bowls. Tint with food coloring. Cover and cool. This makes a very good washable paint for finger painting or window painting!

Nature Rambles and Hikes –

Connecticut Rivers Council

There are plenty of things in nature to collect and a short nature ramble in the backyard or a playground is suggested for the first den meeting and a longer hike for the third meeting. On both occasions, encourage the boys to look, really look, at what they see outdoors every day. Each boy should carry a container to collect such simple things as a

blade of grass, an acorn or other nut, a seed, old leaves, dead insects, twigs, interesting small rocks. When you get back to the meeting place, use field guides to trees, insects, birds, and rocks to try to identify their prizes. Your den's activities will depend in part on where you live - the kinds of flora and fauna that grow there and how advanced springtime is in your area. Wherever you are, there should be plenty to see, hear, and smell in the outdoors.

For many other ideas, see Chapter 8, "Nature and Outdoor Activities," in the Cub Scout Leader How-To Book. You will also find nature related activities in the Wolf Cub Scout Book (Achievements 6 and 7 and Electives 13, 15, 18, and 19) and in the Bear Cub Scout Book (Achievements 5 and 6 and Electives 2, 12, and 15).

AUDIENCE PARTICIPATIONS

How To Build A Thingamajig

Southern NJ Council

Divide audience into four groups and assign each a part. They are to say the phrase for their part every time they hear it in the story or whenever they hear Scatereekus.

Doodads:	Clickety-clack, clickety clack
Dingford:	Whiz, bang, boom
Freedistant:	Whoosh, whoosh
Higoricky:	Snap, crackle, pop
Scatereekus:	All sounds together

Very few families these days can get by without a thingamajig. Sure you can buy one at the local hardware and appliance store, in all sorts of colors, sizes, shapes, makes and models, but as easy as they are to build yourself, you should just get a kit and put it together. Here are a simple set of instructions for building your own thingamajig...

The **Doodads** of the thingamajig kit are stored in the bubble-wrap gizmo and are stapled with the purple assembly **Dingford** to the left-handed **Freedistant**. The assembly **Dingford** should be placed in an upright position on any corrugated doomaflatchy or **Freedistant** to complete assembling the **Doodads**. Carefully remove the gizmo from its containeration of the **Doodads** from the **Freedistant** and lay out the **Doodads** in parallel with the assembly **Dingford** and assemble the **Doodads** in the order listed. You will need two fringhoppers with a 4/3" gagglehump for the **Higoricky**, and you'll have to use penpoppers to complete the riggeration.

Using a witchifiggle, carefully punch 1/2" what-nots through the assembly **Dingford** and **Freedistant**, where the **Higoricky** will attach. The what-nots are there to capitrate the hoosie **Higoricky** that will beefling the **Doodads** together.

Next framemis the chingus to the **Freedistant**, making sure the whatchamacallits are catiwompus to the hootnanny and the **Higoricky**, as shown on the assembly **Dingford**. If it is reversed, the thingamajig will not work properly.

Tighten two fistaroud valves underneath the **Freedistant** using the hickeys from the **Doodads** to on from one doodad to the other. Now refracker a jigger to the demisantis and

the doorfunkey near the whatchamacallits. Put a dings on each loose enough so that the thingamabob can discombobulate and rotate easily, or it might XXXX and fly off and hit someone in the doohickey. That finishes the instructions. If you've followed them carefully, you should have a well running thingamajig. When you turn over the **Scatereekus**.

Rhyming Pairs

Baltimore Area Council

Try asking your audience to come up with these. Or use as a gathering activity by listing on a piece of paper and giving a copy to everyone as they arrive. The answers are sure to produce some laughs. CD

1. Snoopy after earning Boy Scouting's highest award.
2. A scalding cooking vessel.
3. Cubmaster Benjamin's groups of eight Cub Scouts.
4. A Venturing leader's cap bill.
5. Boxing matches featuring the members of a troop.
6. A crooked canvas shelter.
7. A varsity Scout leader's pet insect.
8. A picture made by Cub Scouts passing a crayon on paper over a headstone engraving.
9. Sneezing shallow draft watercraft.
10. Swimming partner with bleeding cut.
11. One of five Scouts with stone material for fire by friction.
12. A camper's wood chopper made of paraffin.
13. Earth-boring animal befriended by a group of eight Boy Scouts.
14. A militant effort to teach emergency medical treatment.
15. Hiker's footgear stuffed with an orange, apple and banana.

Answers:

1) Eagle beagle 2) Hot pot 3) Ben's Dens 4) Advisors visor 5) Scouts' bouts 6) Bent tent 7) Coach's roaches 8) Cubbing rubbing 9) Ah choo canoe 10) Bloody buddy 11) Flint quint 12) Wax ax 13) Patrol mole 14) First aid crusade 15) Fruit boot

ADVANCEMENT CEREMONIES

Pocket Ceremony

Southern NJ Council

As we all know, most boys begin their collections in their pockets. Cub Scouts takes this a step further and uses to pocket on the uniform as a place to build a collection. Here is a pocket - a very plain pocket - not very interesting, and it could belong to anyone. But wait, let's give this pocket to a Cub Scout.

[Narrator places Bobcat badge on pocket.]

Our pocket is turning into something with meaning. It represents a sense of belonging and will soon bring our Cub Scout knowledge, skills, enjoyment and good fellowship. We would like to present the following boys and parents their Bobcat badge.

[Narrator places Wolf & arrows on pocket.]

With the Wolf rank, our pocket turns into something more special. It proudly displays the first symbol of new-found knowledge of the flag, of keeping strong, of tools, of knots of safety, of books and reading. It means our Cub Scout has mastered feats of fun. Tonight we are privileged to recognize the following Cub Scouts who have achieved the rank of Wolf. Would the following Wolf candidates and their parents please come forward.

[Narrator places Bear & arrows on pocket.]

Adding the Bear badge has increased our pocket's meaning even more. It shows our Cub Scout is completing increasingly difficult achievements which show he is growing in knowledge and skill. Would the following Bear candidates and their parents please come forward.

[Narrator places Webelos and Arrow of Light on pocket.]

Our pocket has now had placed upon it the Webelos badge and Arrow of Light, the highest awards which our Cub Scouts can achieve. To receive these awards, our Cub Scouts must dedicate themselves to the hard work necessary in completing the required number of activity badges and prove themselves ready to join the ranks of Scouting. Tonight we wish to recognize these boys who have completed activity areas within the Webelos program. Will the following boys and their parents please come forward.

(With the Webelos Scouts together, a candle ceremony may be added at this time.)

Our pocket is very special now. It is very rich in new possibilities. It opens up a whole new world of challenges. Cub Scouting has taken our plain pocket, and turned it into a pocketful of adventure, fun, and excitement.

Congratulations to all you boys and your parents on your achievements. **LEAD CHEER!!**

Pocket Ceremony #2

Southern NJ Council

Preparation - Pockets of blue paper with different emblems on them ahead of time and hold up as each is referenced in speech).

Young boys and collections—I don't think they can be separated. Their collections hold the treasures of their lifetimes, yo-yos, shooters and aggies, a few baseball cards, and Canadian pennies. When a boy walks home from school anything of interest goes into his pocket to become part of his collection - stones, pine cones, nails, a rusty bolt. What neat stuff!

Unlike other boys' pockets, the pockets of the Cub Scout's uniform cannot only hold a lot of things; they are used to display a boy's accomplishments. Cub Scout achievements can be divided into four categories: God, Country, Family and Self.

A boy can earn separate awards for all these areas:

For God, he can earn the emblem of his faith;

For Country, the World Conservation Award;

For Family, the Cub Scout Family Award;

For Self, the camp, special events, and sports/academic program patches.

The most important part of this colorful shirt is the rank; Bobcat, Wolf, Bear, Webelos, and Arrow of Light. Tonight we have someone/boys who has/have earned...

Present awards to parents to give to boys. Give boys and parents a CHEER for a job well done.

Collections Advancement Ceremony

Baltimore Area Council

Equipment: Your choice of as many of the following you need for the various types of awards being presented: 35mm film canister, egg carton, poster board with some post cards attached, clear plastic "baseball card" collection page with some collectable cards inserted, matchbook, stamp collection album (can be a folded piece of poster board with "stamp collection" printed on the cover, jar with holes punched in the lid. POG holder, etc.

Set-up: Place badges in the baseball cardholder behind the baseball cards. They will be revealed when the page is turned around. Badges can be tucked behind post cards on the poster board or taped into the stamp album or fastened under the lid of the jar. Arrow points could be tucked into matchbooks. Webelos pins can go in the egg carton or the 35mm film canister. *(You get the idea. Modify the sample script below to fit your award needs.)*

Cubmaster: Boys are natural collectors. Aside from being able to collect an amazing amount of dust and dirt in a normal day's activities, boys like to collect things. Bottle caps, pretty rocks, stamps, coins... the list is endless *(hold up jar)*. How many of have had your son come to you with a jar and asked you to punch holes in the lid so he could catch some lightning bugs? Flashing brightly on a summer evening, they are one of the first things that our boys run after. Soon they are reaching higher and higher for the ones just out of their reach *(open jar- and take out Bobcat badges)*. Our new Cub Scouts are just like that. They have earned their Bobcat badges, but, with the help of their parents and families, they will soon be reaching for new heights in the Cub Scout program.

(Call parents and boys up and present Bobcat awards.)

As our boys grow, their horizons are widened. They may receive postcards from friends who are traveling on vacation, and these cards may spark an interest in traveling to far off places *(Pickup poster board and show postcards)*. The boys may choose to collect post cards of all the places they have seen and gone. In the same way these post cards can serve as a visual history of our travels, these Wolf badges serve as a visual reminder of the hard work our boys and their families have done on the wolf trail.

(Call parents and boys up and present Wolf awards.)

As our boys continue to grow, it isn't long before they are choosing up sides to play games. Baseball, basketball, soccer... all of them being spurred on by their favorite sports heroes *(show page of baseball cards)*. It's only natural for boys to collect and trade pictures of their sports heroes. building up a collection that suits them *(turn page around)*. Each of the boys in our Bear Den has chosen just the right mix of twelve achievements out of the twenty-four available to complete his own personalized requirements for the Bear badge.

(Call parents and boys tip and present Bear awards.)

Boys have varied interests, and they will pick up any little thing that interests them. Once they have two of them, they have a collection. Then they need some place to keep them (.show 35mm film canister). Often, a little container just like this one is perfect for keeping a boy's prized collection from getting lost in the washing machine. Coins, paper clips, rocks, marbles... you name it. Every boy will have a different collection that interests him (remove Arrow Points from the film container). That is why the Cub Scout advancement program helps boys to explore a wide variety of interests, and rewards them for completing electives based in these interests.

(Call boys up and present Arrow Point awards with appropriate verbiage for Gold and Silver Arrow Points.)

As our boys get older, their collections grow. They need some way of organizing and displaying their treasures (pick up and show egg carton). A simple display case like this one can be used to sort out any type of small treasure for safe keeping, and then be opened for display (open to show activity pins to be awarded). Our Webelos have worked hard this month to earn these Activity Badges. They have a special "display case" on the shoulders of their uniforms that is perfect for displaying these treasures.

(Call boys up and present Activity Badges with appropriate descriptions for the different pins being awarded.)

Our older boys work on their collections until they are highly refined, and they proudly display the results. Some collections will provide many hours of enjoyment far into the future (.show stamp album). These Webelos have worked for several months as active members of their Den and they have collected the required Activity Badges to earn their Webelos Badge (open stamp album to Show badges). I'm sure they will continue to work hard to continue to refine and polish their fine collection of activity pins as they work hard for their Arrow of Light award.

(Call boys up and present Webelos awards.)

Please, join me in congratulating these boys on their fine collection of awards. I almost forgot to mention one of the best collection holders here. The left pocket of a Cub Scout uniform shirt!

Bobcat Induction Ceremony
Baltimore Area Council

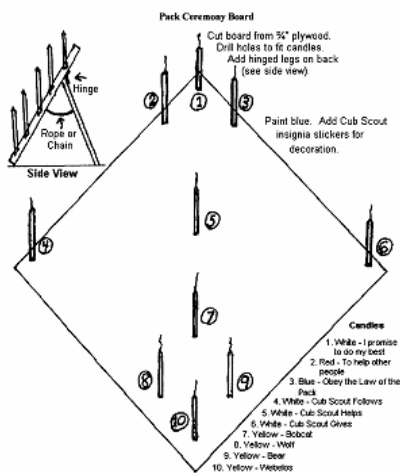

If you are going to make one of these, you'll probably want to copy the picture of the board and enlarge it

Equipment: Pack Ceremony Board with candles

Personnel: Cubmaster, Bobcat candidates, parents

Cubmaster: The top three candles on our ceremony board represent the Cub Scout promise. This is a promise which binds all Cub Scouts together in a common goal. It is through this promise that we are guided and directed.

I light the white candle which stands for "I promise to do my best." This is not always easy to do. Cub Scouts should do the best they can.

I light the red candle which stands for the second part of the promise "To help other people." Helping others not only makes them happy, but it makes the Cub Scouts happy too. You help other people by doing a good turn each day.

I light the blue candle, which stands for loyalty and obedience. The third part of our promise "Obey the Law of the Pack" means that you will follow Akela, who is any respected leader. You will be loyal to our Pack and make the best Pack in the country. You give good will, which means that your attitude of helpfulness and friendship can benefit other people as well as yourself.

Together these three candles represent the Cub Scout Promise, (point to the white candle) I promise to do my best to do my duty to God and my country (point to the red candle), to help other people (point to the blue candle), and to obey the Law of the Pack.

In the center of the board are three white candles representing the Law of the Pack. (Light the 1st candle.) The Cub Scout follows Akela. (Light 2nd candle.) The Cub Scout helps the Pack go; the Pack helps the Cub Scout grow. (Light 3rd candle.) The Cub Scout gives goodwill.

These same three white candles represents the Cub Scouts loyalty to God, Home and Country ...when you give the Cub Scout salute, three of your fingers are hidden (show salute) and those three fingers stand for God. Home and Country. Please give the salute (they do) and remember the hidden meaning,

The remaining candles stand for the ranks of Cub Scouting. We will light the Bobcat candle and additional candles as the other badges of rank are presented tonight.

(Presents Bobcat badge to parents and boy. Handshakes and congratulations all around. Bobcats and parents return to seats.)

GAMES

POCKET COLLECTIONS

Southern NJ Council

Tell the boys ahead of time to wear a pair of pants that have pockets. Now go on a collecting walk. You can only collect what you can put in your pocket; pebbles, sticks, seed, interesting trash, bugs, etc. Come back to the meeting place and lay out your collection. Analyze what you have and separate it into some kind of order. Each boy has a turn talking about his best "pocket find."

Another game that you can include in your collection hike is **Pocket Kim's Game**. Give the boys a few minutes to study the collection and then cover them. Give each one a sheet to write out whatever he can remember. (Or, you can split the den into teams and let them go after it that way)_

NAME AND TELL

Southern NJ Council

Cub Scouts sit in a circle. The first player names a hobby beginning with the letter "A" and tells something about it, and so on, around the circle and through the alphabet.

Examples: "A" is for autographs - ball players are the best. "B" is for bugs - they are creepy crawly, etc.

DOUBLE COIN BALANCE

Southern NJ Council

Ask someone to balance two coins on the rim of a glass at the same time, using only one hand. Here's how to do it: Stand the coins against the side of the glass. Push them up the side with thumb and forefinger. Carefully work the coins over the rim and balance them.

RING RACE

Connecticut Rivers Council

Equipment: Hula hoops, 1 per team.

Divide the group into teams. Have each team line up holding hands. Give a hoop to the person at the head of each line.. At "GO", teammates must pass the hoop along the line, stepping through the hoop and passing it overhead, without letting go of each other's hands. The team that passes the hoop from one end to the other first wins.

"Pieces of Eight"

Connecticut Rivers Council

Equipment: pancake turners, "pieces of Eight" (16 round objects such as pennies), Someone with a timer (watch with second hand or a stop watch).

Each boy takes turn flipping the face-up pennies over to tails using the pancake turner. Fastest time wins. Can be played as a relay race, second player flips all coins back to heads.

Feed the Pumpkin

Connecticut Rivers Council

Place a miniature pumpkin (artificial) on the floor in the corner of the room Give each player five nuts (walnuts, acorns) From a predetermined distance the players toss nuts underhand into the pumpkin. *High scorer could be presented with a chocolate turkey.*

Corncob Darts

Connecticut Rivers Council

Corncobs become colorful, harmless darts for games and contests. Take a 3" to 4" section of corncob and bore a hole through one end. Cut different colored crepe paper ribbons and put them through the bole in the side of the cob so they trail 12 to 15" on each side. The darts are ready to be thrown at a target.

Turkey Feather Relay

Connecticut Rivers Council

Divide the group into teams, relay style. First player in each team holds a turkey feather. On signal, he throws his feather, javelin style, towards the finish line. As soon as it comes to earth, he picks it up and throws it again, repeating until he crosses the finish line. He then picks up the feather and runs

back to his team and passes the feather on to the next player, First team to finish, flaps their arms and gobbles like triumphant turkeys.

Whistling -Contest

Connecticut Rivers Council

Fairs were held each year at Williamsburg during colonial times. One of the attractions was a whistling contest Contestants were given tunes to Whistle, if they laughed or lost the tune. they were out of the contest Try it in your den or pack using a tune that most boys wilt be familiar with.

SONGS

PICK IT UP

Southern NJ Council

(Tune: Caisson Song)

Over hill, over dale,
We will fill our pockets full,
With whatever we pick off the ground.
Dirt and mud, bugs and snails,
You will never see us frown.,
As we pick it up off of the ground.
And it's hi, hi, ho.
What fun it is for me.
Gathering up string and tree moss.
Where 'ere we go, you will always know,
That we pick it up off of the ground.

WHAT IS IT?

Southern NJ Council

(Tune: Auld Lang Syne)

I found it in an old tree stump,
I found it in a tree.
I put it in my right pocket,
So no one else could see.
I left it there all through the night
It stayed there through the night.
I took it out the next day,
And showed it to my mom.
She couldn't understand just why
I had it in my pants.
I told her that I had it there,
So no one else could see.
She made me put it back outside.
It didn't belong inside.
It lives inside the old tree stump
With other snakes alike.

LOOK INSIDE

Southern NJ Council

(Tune: Battle Hymn of the Republic)

When I was eight years old, I found a big fat frog.
Later on I found a garden snake beneath a fallen log.
I found so many items that I keep them all inside
The pockets of my jeans.

CHORUS

Pockets, Pockets are so glorious.
Pockets, Pockets are so glorious.
There you find a lot of interesting things.
My pockets are just fine!

WHAT'S INSIDE?

Southern NJ Council

(Tune: Supercalifragalistic)

My Mother asked me one fine day just what I had inside.
 My pockets were so very full, they bulged from side to side.
 I told her that she didn't want to know the answer yet.
 For they are special things to me, my lifelong super pets.
 A rubber ball, a piece of string, a candy wrapper too.
 Some bubble gum, a coke pop-top; Mom doesn't have a clue.
 But buried deep inside my pants; my very dear close friend.
 My horny toad will be my friend, until the very end.

Competition Song*Connecticut Rivers Council*

(Tune: When The Saints Go Marching In)

Oh, when the Pack begins to sing;
 Oh, when the Pack begins to sing;
 Sometimes, I just can't tell who's the loudest;
 When the Pack begins to sing!

(Each Den in turn:)

Oh, when Den ____ begins to sing:
 Oh, when Den ____ begins to sing:
 We're gonna try to sing out the loudest;
 When Den ____ begins to sing:

Add verse or two, such as –

Oh, when the parents begin to sing; - etc
 Oh, when the Pack sings all together;
 Oh, when the Pack sings all together;
 That's when we always sing the PROUDEST;
 when the Pack sings all together!

Twelve Days of Christmas*Baltimore Area Council*

Although this song is a month early for Christmas, it does fit this month's theme. This type of song is known as a "collective." Maybe with some imagination you can make it fit even better – Change Christmas to "November" or "this theme", or "this month"

On the first day of Christmas, My Cub Scout brought to me,
 An invitation to a party.
 On the second day of Christmas, My Cub Scout brought to me.
 Two handmade ornaments, And an invitation to a party.
 On the third day of Christmas, My Cub Scout brought to me.
 Three pine cones, Two handmade ornaments, etc....
 On the fourth day of Christmas, My Cub Scout brought to me.
 Four beads he earned...
 On the fifth day of Christmas, My Cub Scout brought to me.
 Five songs to sing...
 On the sixth day of Christmas, My Cub Scout brought to me,
 Six more things to bake...
 On the seventh day of Christmas. My Cub Scout brought to me.
 Seven skits to practice...
 On the eighth day of Christmas. My Cub Scout brought to me,
 Eight great big hugs...
 On the ninth day of Christmas, My Cub Scout brought to me.
 Nine good deeds...
 On the tenth day of Christmas, My Cub Scout brought to me.
 Ten minutes to rest...
 On the eleventh day of Christmas My Cub Scout brought to me.
 Eleven loving words...

On the twelfth day of Christmas, My Cub Scout brought to me,
 Twelve more months of Scouting...

Turkey Song Tune: Bring Back My Bonnie*Baltimore Area Council*

My Roundtable staff knows I have an aversion to songs based on "My Bonnie" This is the only "My Bonnie" based song I allow in my Roundtables. CD

My turkey went walking one morning
 The November weather to see
 A man with a hatchet approached her.
 Oh bring back my turkey to me.

Chorus:

Bring back, bring back
 Oh bring back my turkey to me, to me.
 Bring back, bring back.
 Oh bring back my turkey to me.

I went down the sidewalks a shopping
 The sights in shop windows to see.
 And everywhere hung great fat gobblers,
 Oh bring back my turkey to me.

Chorus:

I went out to dinner and ordered
 The best things they had I could see
 They brought it all roasted and sizzling,
 They brought back my turkey to me. ,

Chorus:

Brought back, brought back
 They brought back my turkey to me, to me.
 Brought back. brought back
 They brought back my turkey to me.

Turkey Dinner*Connecticut Rivers Council*

Tune: Are you sleeping

Turkey dinner, turkey dinner
 Gather round, gather round.
 Who will get the drumstick?
 Who will get the wishbone?
 All sit down, all give thanks.

Over the Freeway*Connecticut Rivers Council*

Tune: Over the River

Over the freeway and through the smog
 To grandmother's house we go.
 My dad knows the way to drive around
 Thru the traffic that is slow--oh?
 Over the freeway and through the smog
 Drive fast my car of gray.
 I'm awfully hungry, ready to eat,
 For this is Thanksgiving Day!
 Over the freeway and through the smog
 And straight through the toll man's gate.
 We seem to be going ever so slow.
 It's so very hard to wait!
 Over the freeway and through the smog
 Now grandmother's house I spy.
 Hurrah for the fun Is the turkey done?
 Hurrah for the pumpkin pie!

An Alphabet Of Names*Southern NJ Council*

(Tune: If You're Happy and You Know It)

If your name starts with A, turn around.
 If your name starts with B, touch the ground.
 If your name starts with C, then stand up and touch your knee.
 Clap your hands if your name starts with D.
 If your name starts with E, wink your eye.
 If your name starts with F, try to fly.
 If your name starts with G, blow a kiss up here to me.
 If your name starts with H, say "Hee, hee!"
 If your name starts with I, wave your hand
 If your name starts with J, shout, "It's grand"
 If your name starts with K, stand and shout out loud, "We're here"
 If your name starts with L, tug your ear
 If your name starts with M, make a smile.
 If your name starts with N, shake a while.
 If your name starts with O, put an elbow on your nose.
 If your name starts with P, say, "I know!"
 If your name starts with Q, raise your hand.
 If your name starts with R, you should stand.
 If your name starts with S, you should pat your head, I guess.
 If your name starts with T, say "Oh, yes!"
 If your name starts with U, touch your eye.
 If your name starts with V, pat your thigh.
 If your name starts with W, with X or Y or Z,
 Then stand up and take a bow and say "That's me!"

Silver Arrow*Baltimore Area Council*

(This Old Man)

This Cub Scout he earned one
 He has all his projects done

Chorus:

With a tweet tweet, toot toot on a flutophone
 This Cub Scout came skipping home.

This Cub Scout, he earned two,
 He made boats and airplanes too.

Chorus (Repeat after each verse)

This Cub Scout, he earned three
 He earned 30 points you see.

This Cub Scout he earned four
 Here's a Cub that knows the score

This Cub Scout he earned five
 Here's a Cub that's sure alive.

This Cub Scout, he earned six
 Here's a Cub That is full of tricks.

This Cub Scout, he earned seven
 He is way up in Cub Scout heaven.

This Cub Scout, he earned eight
 Here's a Cub that's really great

This Cub Scout, he earned nine
 Here's a Cub that's doing fine

This Cub Scout, he earned ten'
 He just joined the Webelos Den.

This Cub Scout He's eleven
 He's a Boy Scout – Thank you, Heaven

On to Scouting*Baltimore Area Council*

(She'll Be Comin' Round the Mountain)

In their Pow Wow Book, Baltimore Area Council acknowledges this song being from a 1959 CS program quarterly. They modified it replacing "Lion" with "Webelos" I lowered the ages to match the usual age for the grade if you run an age based program, you can easily shift the ages to match your program. CD

He'll become a little Bobcat when he's seven,
 He'll become a little Bobcat when he's seven,
 He will come to all our meetings,
 and he'll smile at all our greetings.
 He'll be quite a handsome Bobcat when he's seven.

He'll become a fearsome Wolf before he's eight,
 He'll become a fearsome Wolf before he's eight.
 He will snarl and bark and grow-w-w-I,
 and he probably will how-w-w-I,

He will make us very proud before he's eight.
 He'll become a great big Bear before he's nine.
 He'll become a great big Bear before he's nine.
 He will have a fascination for each item in creation.
 He will have a million questions before he's nine.

He'll become a Webelos strong when he is nine,
 He'll become a Webelos strong when he is nine,
 He will learn to give to others
 and he'll have a Den of brothers.
 He's a strong and happy Webelos when he's nine.

We will send him on to Scouting at eleven,
 We will send him on to Scouting at eleven.
 We will wish him happy Scouting
 at a special Cub Scout outing,
 This is pretty close to heaven at eleven.

And some Webelos Songs –**For Scientist -****Cub Scout Scientist***Baltimore Area Council*

(Tune: My Bonnie)

The scientist works with his theories
 The scientist works in his lab
 The Cub Scout learns by discovery
 The answers to questions he's had.
 Mix this. mix that
 The scientist tests his theories
 Try this, Try that
 The Cub Scout makes a discovery.

A Little Piece of Wood*Baltimore Area Council*

(Tune: if You're Happy and You Know It)

Oh I wish I was a little piece of wood.
 I really feel that it would feel so good.
 If I was a little table.

That was made from solid maple.
 Oh I wish I was a little piece of wood.
 Oh I wish I was a little piece of wood.
 I really feel that it would feel so good.
 I'd be a grandfather clock.
 Made from oak and go tick tock.
 Oh I wish I was a little piece of wood.
 Oh I wish I was a little piece of wood.
 I really feel that it would feel so good.
 I could be a seaman's chest.
 Made of white pine that's the best.
 Oh I wish I was a little piece of wood.

For Craftsman -**Toolbox Song**

Baltimore Area Council
 (Tune: I'm a Little Teapot)

I'm a pair of pliers just because
 Here is my handle, here are my jaws.
 Keep me in your toolbox bright and new
 Take me out and I'll work for you.
 I'm a big strong hammer, a mighty tool.
 Hit the nails only, that's the rule.
 Keep me in your toolbox bright and new
 Take me out and I'll work for you.
 I'm a happy C-clamp, tell you what I do.
 I eat board sandwiches filled with glue.
 Keep me in your toolbox bright and new
 Take me out and I'll work for you.
 I'm a handy wood plane. Give me a try.
 I can help you out if your door's too high.
 Keep me in your toolbox bright and new
 Take me out and I'll work for you.

CUB GRUB**QUICK PEANUT BUTTER FUDGE**

Connecticut Rivers Council

For each Scout:

- 1 1/4 Tbsp margarine
 - 2 Tbsp Karo red label syrup (light)
 - 1 1/2 Tbsp Peanut Butter (creamy or chunky)
 - 1/4 teaspoon vanilla
 - 1/8 teaspoon salt
 - 1 cup plus 2 Tbsp confectioners sugar
 - 2 Tbsp chopped nuts
1. Blend margarine, corn syrup peanut butter, salt and vanilla in mixing bowl.
 2. Stir in confectioners sugar gradually.
 3. Turn onto board and knead until well blended and smooth.
 4. Add nuts gradually, pressing and kneading into candy.
 5. Press out with hands into square 1/2 inch thick.
 6. Cut into serving pieces.
- Makes 1/2 pound fudge per scout.
 Make for fun or make as gift for parents. Wrap in saran and decorate with ribbon or make a special decorated boy or candy dish to put fudge in. Remind scouts to refrigerate once the gift is taken home.

Kangaroo Pocketful of Goodies

Southern NJ Council

1/2 to 1 pocket bread per scout, 1/4 to 1/2-cup chicken or turkey per scout, tomato slices if they want, 1 TBS chopped walnuts, mayonnaise or salad dressing, lettuce, 1 slice cheese per scout

Slice the pocket bread in half (if using a whole per scout) open it. Spread mayonnaise or salad dressing in center. Add turkey or chicken and cheese slice. Cook in microwave for 30 - 40 seconds for 1/2 or 1 minute for a whole pocket. Insert slices, lettuce, and chopped walnuts.

Hot Pockets (the easy way)

Southern NJ Council

Ingredients - 1 package crescent rolls, Pizza Sauce, Pepperoni, Cheese

Cut up the pepperoni and cheese. Spoon a spoonful of pizza sauce on one crescent roll. Put some pepperoni and cheese in the center and fold over and smash edges together with a fork. Cook 375 degrees for 15 - 18 minutes You can also use the 'same idea for peanut butter and jelly, pie filling etc.

Pita Sandwiches

Southern NJ Council

1 package Pita Bread, any meat and cheese lettuce pickles salad dressing, mustard (any other sauces) tomatoes
 Cut Pita Bread in half, open up and spread salad dressing on both sides, add mustard, cheese, meat, pickles, lettuce, tomatoes, (and any other filling you like)

Ice- cream Sandwiches

Southern NJ Council

Make your favorite peanut butter cookie recipe or buy peanut butter cookies - For each ice-cream sandwich, press 1 rounded tablespoon ice cream between 2 cookies. Put sandwiches in rectangular pan and freeze uncovered about 1 hour or until firm. If you would like roll the edges of the sandwiches in candies or chopped dry roasted peanuts. Wrap each sandwich in plastic wrap. Store sandwiches in freezer in plastic freezer bag.

STUNTS AND APPLAUSES**CHEERS**

Southern NJ Council

- Turkey 1** - Say, "Gobble, gobble, gobble," then rub stomach and say, "Yum, yum."
Turkey 2 - Put hands under armpits to make wings, flap wings and yell, "Gobble, gobble, gobble."
Sword - Pretend to have a sword in your hand. Swing it across your body three times saying, "Swish, swish, swish!"
Cheese grater - Act as if your are grating cheese and say "Great, great, great, great!"
Palm Tree - Stand like a tree with palms up.

Connecticut Rivers Council

Bouncing Ball: Using a golf ball (preferably) Have the group yell 'Pow' every time the ball hits the floor when dropped initially from an outstretched hand above the head, or thrown up.

Cheese Grater: Act as if your are grating cheese and say "Great, great, great, great!"

Friendship Applause: Have your neighbor put his left hand out to his side, and you clap it with your right hand; meanwhile you are also holding out your left hand and your other neighbor is clapping with his right hand, etc.

Good Citizen: "Give yourself a pat on the back."

The Mayflower Applause: Wave hands back and forth way above head as if they were sails on a ship while saying "Shosh, Shoosh"

Pilgrim cheer: Turn to your neighbor to your left; shake hands once while saying Thank You. Turn to your right and do the same, now turn to the person to whom the cheer is intended, hold out your hand as if to shake hands and say thank you.

RIDDLES

Southern NJ Council

Why was the turkey the drummer in the band?

Because he had drumsticks!

Why did the Pilgrims want to sail to America in the spring?

Because April showers bring mayflowers!

What key has legs and can't open doors?

Turkey!

If April showers bring Mayflowers what do Mayflowers bring?

Pilgrims!

RUN ONS

The Stamp Collector

Connecticut Rivers Council

Billy, a nine year old, took up the hobby of collecting stamps. He was very enthusiastic about it until one day his neighbor's kid saw his impressive collection and took up the hobby.

Billy complained to his Dad: "I don't want to collect stamps anymore! Andy has every stamp that I have!"

"Don't be stupid, son", his dad said. "Don't you know that imitation is the best form of philately."

Southern NJ Council

Cub enters Singing – "Soap.. . soap. . soap"

Cubmaster asks – "What are you doing?"

Cub replies – "Oh, just singing a few bars!"

Baltimore Area Council

1st Cub: I was going to get you a pocket calculator for your birthday.

2nd Cub: How thoughtful of you.

1st Cub: But I changed my mind. I thought you already knew how many pockets you had.

Stick Stunt

Southern NJ Council

Boy: (Comes on stage with stick in his hand. He puts the point of the stick down on the floor, picks it up, puts it down in another place.)

Leader: What are you doing?

Boy: Oh, I'm just sticking around.

Trapper Trails Council

Knock, Knock

Who's there'?

Would he

Would he who?

Woody Woodpecker (do Woody Woodpecker call)

Knock, Knock

Who's there?

Ketchup

Ketchup who?

Ketchup to me if you can

Knock, knock

Who's there'?

Thistle

Thistle, who?

Thistle, be the last Knock, knock joke.

STUNTS

If Dr. Seuss Were In Technical Writing...

Connecticut Rivers Council

Try saying this aloud to those at your Pack Meeting –

Here's an easy game to play.

Here's an easy thing to say:

If a packet hits a pocket on a socket on a port, And the bus is interrupted as a very last resort, And the address of the memory makes your floppy disk abort, Then the socket packet pocket has an error to report!

If your cursor finds a menu item followed by a dash, And the double-clicking icon puts your window in the trash, And your data is corrupted 'cause the index doesn't hash, Then your situation's hopeless, and your system's gonna crash!

You can't say this? What a shame sir! We'll find you Another game sir.

If the label on the cable on the table at your house, Says the network is connected to the button on your mouse, But your packets want to tunnel on another protocol, That's repeatedly rejected by the printer down the hall, And your screen is all distorted by the side effects of gauss, So your icons in the window are as wavy as a souse, Then you may as well reboot and go out with a bang, 'Cause as sure as I'm a poet, the sucker's gonna hang!

When the copy of your floppy's getting sloppy on the disk, And the microcode instructions cause unnecessary risk, Then you have to flash your memory and you'll want to RAM your ROM. Quickly turn off the computer and be sure to tell your mom!!

SKITS

THE SPECIAL COLLECTION

Southern NJ Council

I saw variations of this skit in almost every Pow Wow Book. Some had boys talking about their Dad's. So use your imagination and adapt this skit to your group. CD
Cast: Six Cub Scouts, named Bobby, Bill, Tom, Jim, Danny and Mike and a Den Leader. A Cub Scout could play the Den Leader, if you wish. This skit is flexible so you can add or subtract parts to make sure every boy in the den has a part.

Setting: Cub Scouts are discussing their hobbies with their den leader at a den meeting.

Den Leader All right boys, today I'd like you to answer roll call with the name of your hobby. Then we'll see if we can learn the scientific name for that hobby. Bobby, you're first.

Bobby I collect coins. I think that's called numismatist!

Den Leader Very good, Bobby. Bill, you're next.

Bill Well, we collect stamps in my family. And I've heard my dad called a philatelist.

Den Leader That's right, Bill. Now Tom, what's your hobby?

Tom My brother and I like to hike and watch birds. That's called an ornithologist.

Den Leader That's right, Tom. Very interesting. Jim, what do you collect?

Jim My dad and I collect fossils. That's called a paleontologist.

Danny *(Waving his hand)* My brother and I have a garden. We grow things scientifically. We're horticulturists.

Den Leader That's good Danny. And now Mike, what kind of special hobby do you have?

Mike *(Scratching head)* Well, I don't have a special hobby, but I bet you'll never guess what my dad collects! It doesn't have a fancy name. *(Grins a little. Other boys look at each other, whisper and shrug shoulders.)*

Den Leader We give up, Mike. What kind of collector is your dad?

Mike I knew you'd never guess. He's a BILL COLLECTOR!

ALL *(All clap hands to foreheads and leave.)*

Crazy Collecting

Baltimore Area Council

Actors pantomime the different types of collectors as the narrator introduces each one. The narrator may start with something like this:

NARRATOR: Everyone collects things. You collect things. I collect things. Let's take a look at some things other people collect.

The following are samples of collectors you might pantomime have the boys use their imagination to come up with others

A mother collects dirt *(mother in housework clothes mops across stage)*

A coin collector collects coins *(bank rubber crosses stage with sack of coins looking around nervously for The Law)*

Dogs are among the greatest collectors. They collect FLEAS *(actor dressed as dog rolls across stage scratching)*

Now, teachers, they collect papers, of course *(harried teacher runs across with reams of paper spilling out on all sides)*

(These are some ideas. You add other 'collectors.')

End with: The greatest collector of them all (An actor staggers across the stage loaded down with everything from soup to nuts, literally! He can be carrying a washing machine part and dragging a car fender. Let your imagination go! A big sign on him reads: "Junk Man.")

How to Make a Paper Boat

Baltimore Area Council

Folding Instructions: Take a full sheet of newspaper, folded on the center crease with the folded edge away from you. Take the two upper corners and fold them so that they meet at exact center, Fold the remaining flaps up, one on each side. 'Fold and tuck in remaining points.

Continue refolding following the illustrations outlined below for the various stages of the story.

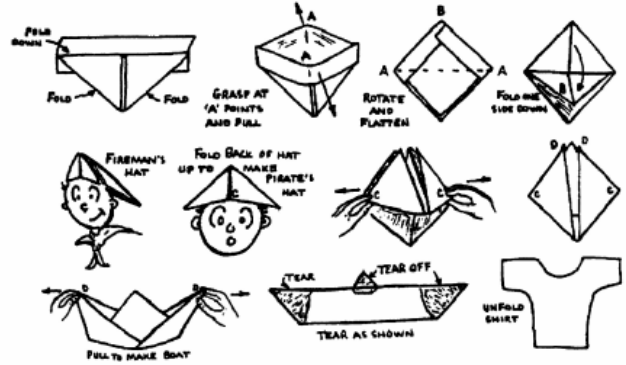

Pirate Skit Using Folded Newspaper

Once there was a little boy who wondered who he would like to be when he grew up. He thought he might like to be a soldier and put on his hat and began marching up and down.

He soon grew tired of this and when a bright red fire truck screamed by, he was sure he would like to be a fireman, He donned his hat and ran after the truck. The fire was soon out, and he began to look around for something else to do.

He realized he was near the ocean, so he put on his pirate's hat and went hunting for treasure along the shore. The weather was stormy, and he saw a ship being tossed around off shore, The ship hit a rock, and the bow was ripped off; Then it was whipped around, and the stern was demolished. To make things worse, a bolt of lightning came and knocked off the mast. The boy rubbed his eyes and saw that all that was left was the Captain's shirt.

The Disappearing Banana

Southern NJ Council

Equipment: 4 or more bandannas and 1 very ripe banana
Personnel: 5 (or more) deadpan assistants and an announcer

Setting: Tell the audience that a magic trick is going to be performed for their enjoyment. Before their eyes, the assistants will demonstrate the disappearing bandanna trick. The assistants have been carefully selected for their ability to follow instructions exactly for their ability to follow instructions exactly. (The assistants take their places behind the announcer. Bandannas are concealed in the hip pocket. The banana is carefully kept behind the one assistants back.)

Announcer: (Straight face at all time) "Remove the bandannas from your pockets and show them to the audience." (Assistants hold the bandannas in front of them, showing both sides. The one with the banana shows the banana with confidence.)

Announcer. "Fold the bandanna in half. (Everyone folds their bandanna one time. The one with the banana begins to look concerned, rolls his eyes left and right and then looks skyward. With an 'oh, well', attitude, he breaks the fruit in half.)

Announcer: "Fold the bandanna in half again." (Everyone folds their bandanna again to a smaller square. The one with the banana expresses more concern, looks left

and right, uses facial expressions to demonstrate an uncomfortable feeling--remember to keep a straight face. He breaks the banana again.)

Announcer: "Hold the bandanna in your left hand and fold the four corners in." (Everyone complies. The one with the banana sort of scoops up the fruit and piles it in the center of the palm of the left hand. Facial expressions should be indicative of extreme concern that something he is doing is different from everyone else.)

Announcer: "Make a fist!" (By now, everyone in the audience is watching the banana. The hands with the folded bandannas are discreetly exchanged--left for right--and the bandannas are placed in hip pockets. By now, the banana is oozing from between the fingers, and the audience is usually in tears.)

Announcer: "Open your hand, and show that the bandanna has disappeared. (Of course, it has, and applause is appropriate.)

Making A Cub Scout

Southern NJ Council

This is an excellent opening for the induction/introduction of new Cub Scouts into a Pack.

Characters: Child, Two Leaders, Two Parents

Props: You will need a large table for the child to lie on during the "operation." The "doctor" can carry a large cardboard knife. Props to be "removed" are tacked to back of table, out of sight. Those to be "put in" can be placed nearby. (Props are listed where used.)

Narrator: We are about to instruct you in the method of making a Cub Scout. To complete this project, you will need one small eager boy, two interested parents, one patient Den Leader, and one courageous Cubmaster.

(Each character enters as his name is spoken. Boy wears uniform under a large loose-fitting shirt and climbs up on the table. Others don surgical masks. As the narrator continues, the operation proceeds, with Cubmaster acting as doctor. Den Leader and parents hand him the things to be put in and take the things removed. When the boy is hidden under a sheet, he removes his shirt.)

Narrator: Cover him with fun and good times (Hold up posters labeled "FUN" and "GOOD TIMES" and cover boy) We use laughing gas for anesthetic. *(Use a tire pump labeled "Laughing Gas.")*

Take out hate and put in Love. *(Hate - lump of paper, so labeled. Love - big paper heart, labeled).*

Take out selfishness, put in cooperation. *(Sign "I," sign "WE).*

Take out idle hands, put in busy fingers. *(Idle - empty rubber gloves. Busy - glove full of flour.)*

Take out laziness, put in ambition. *(Laziness - rag; Ambition - blown up balloon.)*

After this pleasant operation, we have a "CUB SCOUT." *(Remove the sheet. Boy, in uniform, stands up and gives the Cub Scout sign.)*

CLOSING CEREMONIES

Pocket Collections

Southern NJ Council

Personnel: 7 Cubs

Equipment: Cards with letters spelling out **P O C K E T S** and pictures of collections or the real things. Have the words on the back of the cards in **BIG** print.

Cubmaster: As we have seen at tonight's Pack Show, Cub Scouts collect many things. Let's have a recap before we go home -

Cub # 1: P: is for **POSTAGE** stamps, something people have collected for many years.

Cub # 2: O: is **OLD-FASHIONED**, what some call antiques.

Cub # 3: C: is for **CARDS**, baseball, football, basketball or hockey. There are so many kinds to choose from.

Cub # 4: K: is for **KITES**, to fly high in the sky. They come in so many styles and color the variety is endless.

Cub # 5: E: is for **ELECTRONICS**, some people collect everything electronic they can get their hands on. TVs, radios, CD players, video games and computers the list goes on.

Cub # 6: T: is for **TOYS**, every kid is a true collector. Their collecting never stops even when they grow up. They just collect different toys.

Cub # 7: S: is for **SCOUT** stuff, that every Scout collects. What Scout does not have collections of badges, patches, uniforms, ties slides, T-shirts, and camping gear.

Cubmaster: Thanks for coming. Hope you enjoyed the show. Good night

Collection Closing Ceremony

Equipment A single twig and a bundle of twigs

I hold in my hand several twigs. You can see that one twig alone is easy to break (demonstrate by breaking a single twig in two), but when I collect a bunch of twigs and bundle them together, they are almost impossible to break (make an unsuccessful effort to break the bundle of twigs). There is strength in numbers. As a nation - *a collection* - of people working together to preserve our freedom and heritage, we can keep our country strong.

Please stand with me and honor the symbol of our great country as we retire the colors. Color Guard, advance and retire the colors.

The Magic Candles

Connecticut Rivers Council

Set Up - On head table are arranged magic candles, which should be lighted as ceremony begins

Narrator: Our candle stands tall, straight and white. It burns and gives forth inspiring light. As its light shines forth, you will see our colors blue and gold are regal as can be. As the blue appears, think of truth and loyalty, the sky so blue, steadfastness and spirituality. When the gold shines forth, be of good cheer and think of happiness and sunlight so clear. As our candle's flame reaches toward the sky so blue, let us

ask our God to give us wisdom to lead each boy straight and true. Mold each of us to be like our candles, straight and tall, and be inspired to give to God and our country our all. (To make "magic candles" use tall white candles. Drill 1/4" diameter holes every two inches down opposite sides of the candle. Place scraping of blue and gold crayons in the holes. Melt paraffin and whip with eggbeater. Cover candle with whipped paraffin using a fork to give the candle a rough decoration. As the white candle burns it will drip blue and gold wax decoratively down the side of the candle.)

Cubmaster's Minute

COLLECTIONS THOUGHT

Southern NJ Council

Many people of all ages have discovered the fun of collecting things. Whether you collect rocks or stamps or model cars, it's exciting to be on the watch for a new item to add your collection and to see that collection grow. Some collections, such as rare sports cards, can be worth a lot of money. Other collections have no great dollar value. But there is one thing that you can collect which is worth more than anything else; good turns. In the Cub Scout Law of the Pack, we say, "The Cub Scout gives good will." That means that a Cub Scout is always on the lookout for ways to be helpful and kind to other people. When you accumulate acts of good will toward others, you are the wisest collector of them all.

Be Prepared

Southern NJ Council

Have Cubmaster pull out the collection of stuff he/she carries in his/her pockets and explain why it is carried and how it helps one be prepared for emergencies with it. Then conclude with –

Cubmaster: Everything a boy collects in his pockets or elsewhere is important to him, just as he and his family is important to our pack. We have to work together to be successful, if our pack is successful, each of us will feel good about ourselves and each other. Let's remember to be prepared by what we carry in our pockets and our lives and be successful.

WEBELOS

Webelos Activity Badge Ceremony Ideas

Baltimore Area Council

AQUANAUT - If the Pack meeting is held at a pool, have the boys swim across the pool to receive their badge. If inside, have them demonstrate a swimming stroke and pretend to swim to you to receive his badge.

ARTIST - Webelos leader is dressed as an artist and pretends to paint portrait of the Webelos as he is sitting on a stool posing. He puts down his palette and paintbrush and says "Each boy is a masterpiece." He then hands the boy a pre-made silhouette of the boy and the activity badge he has earned.

ATHLETE - Do a standing long jump and catch badge that the Webelos Leader is holding at arms length.

CITIZEN - The Webelos Leader dressed as judge, pounds gavel on table and says, "Hear ye, Hear ye, Hear ye. I present to you on this day of in the year of Our Lord. 20_____, (boy's name) as a new citizen of our Pack and community."

COMMUNICATOR - Webelos leader uses sign language to tell what the activity badge is. He gives the badge to the Webelos Scout who thanks him in sign language also.

CRAFTSMAN - Webelos leader and boys are busy building crafts and leader says, "Well boys, we've sure had a busy month making all these things, but I think we have made more than just toys. We have come a step closer in making you young men." He then gives them their badge.

ENGINEER - Several boxes with the name of Pack Officers (Cubmaster, Den Leader, Committee Chairman, etc.) are scattered around. The Webelos Den Leader comes on stage and picks up a box and reads out loud what it says, and then places it back on the floor facing the audience. Start with the committee members first. Build the boxes up in the shape of a pyramid. As the name of a boy is read that has earned the activity badge he comes forward and is given the badge. His leader congratulates him on the achievement and tells him how great it is that he can be part of the Cub Scout pyramid.

FAMILY MEMBER - The Webelos Leader calls the Webelos Scout and all the members of his family including brothers, sisters, and aunts, uncles, etc. He lines them all up according to size from the tallest one next to him to the smallest one next to the Webelos Scout. He then says "Since this activity badge was earned with the help of all the family, I will give it to the tallest member of the family. Each of you will pass it down the line until it reaches the Webelos Scout."

FITNESS - Do a sit up and reach out and take the badge that is being held at the end of his feet. (Just far enough to give him a good stretch before getting it.)

Do a push-up. The boy will pick up the badge with his mouth as he lowers himself to the floor, and as the Webelos Leader is holding the badge near the floor beneath the boy.

FORESTER - The Webelos Leader has all the activity badges attached to a branch of a tree. he says "I am presenting you this activity badge in the hopes it plants a seed of knowledge that will grow with time."

GEOLOGIST - Webelos Leader is examining several large rocks that are out on the table. He comes to the largest one and picks up a hammer and chisel, and proceeds to chisel on the rock. He removes an award from the rock and calls forward the boy who is to receive it. The chiseling continues until all awards are presented.

HANDYMAN - The Webelos Leader rolls on old tire out. Inside the tire are the activity badges. He says, "This tire is old. It has served its purpose. We have in our midst, several future mechanics." He calls up the boys who have earned the badge and takes the badges out of the tire and presents them.

NATURALIST - Webelos leader is inspecting insect collection and notices something different and out of place, "What is this? I don't remember seeing this before. Oh, (boys name) this must belong to you for earning your Naturalist Activity Badge."

CRAFTSMAN TECHNOLOGY GROUP

Baltimore Area Council

The requirements for the Craftsman activity badge include projects in wood, leather and tin. This activity helps the boys develop confidence in their abilities by encouraging them to use their talents and skills for more advanced handicraft projects, or perhaps to develop a hobby in one of these mediums.

Where to Go and What to Do

- ✓ Visit a furniture factory, sawmill, lumberyard, or cabinetmaker.
- ✓ Visit a tannery or leather goods manufacturer.
- ✓ Demonstrate the proper care and use of tools.
- ✓ Demonstrate metal work, using a tin snips and vise.
- ✓ Have a nail-driving contest.
- ✓ Make a tool chest.

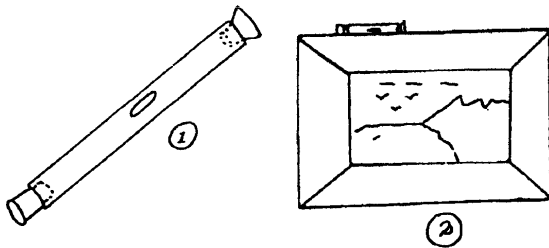

Carpenter's Level

Southern NJ Council

You can make a carpenter's level out of a glass tube - like dentists use or the kind of plastic tube a toothbrush comes in. With the vial from the dentist's office, remove one rubber cork from the end. Rinse tube out good and then fill almost full of water and replace cork.

With a glass or plastic tube, cork one end, fill nearly full with water, then cork the end. (pic 1.)

Lay tube on a flat surface. If this surface is perfectly level, the bubble inside the tube will be exactly in the middle. If the surface is not quite level, the bubble will be off center one way or the other. (pic 2.)

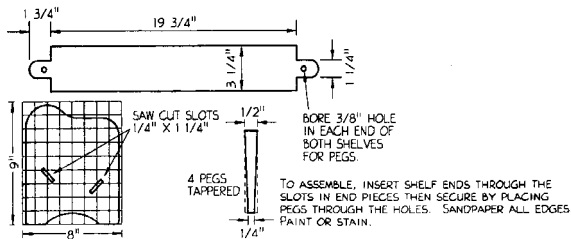

Book Trough

Southern NJ Council

Copy picture and enlarge. Then trace diagram of book ends onto 3/8" board or plywood. Cut shelves from measurements. Make ends identical by clamping together before cutting and finishing.

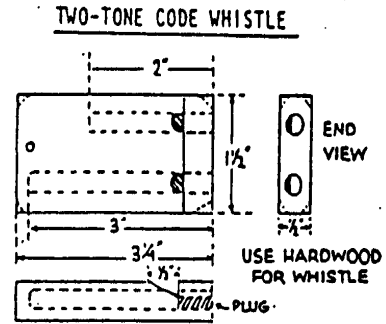

Two-Tone Code Whistle

Southern NJ Council

You can work out a series of code signals with this two-tone code whistle. The twin tones make it penetrate a long distance. Each hole may be used independently or both may be blended.

Walnut, maple or birch are good hardwoods to use. Make sure the holes are completely free of sawdust. Round off all edges and sand it smooth, then attach a neck strap lanyard long enough so that you can tuck the whistle into your shirt pocket.

Note that the plugs are flattened off at the top. Plugs should make a tight fit for the best resonance.

1. Drill holes as indicated in piece of hardwood. Cut air escape notch.
2. Insert 1/4-inch plugs flush to straight cut of notch. Cut off excess wood.



Mountain Cabin Bookends

Baltimore Area Council

Using 3/4" wood, cut one back 4" x 6", one base 3" x 4", one cabin and one tree for each bookend. See pattern pieces. After making pieces, assemble and paint as desired.

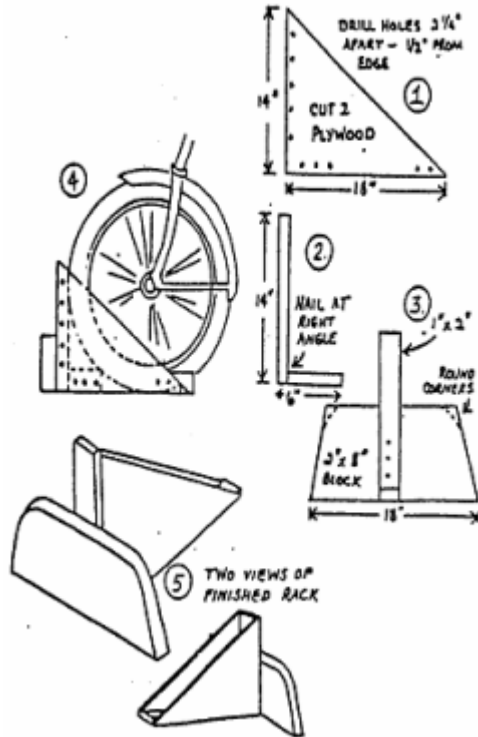

Personal Bike Rack
Southern NJ Council

Materials:

- One 14" x 18" piece of 1/2" plywood;
- One 1" x 2" x 2"; one 2" x 8" x 18"
- No. 6 flathead screws (1-1/4" long);
- Six-penny nails;
- Varnish or paint;
- White glue or powdered resin glue.

1. Cut plywood triangles. Drill holes as show with a 5/32" drill bit. Paint or varnish the inside of plywood at this time. It will be difficult to do after rack is assembled.
2. Cut the 1" x 2" pieces. Nail the two longest pieces at right angles.
3. Cut the 2" x 8" piece. Attach the nailed 1"x2" with screws. Paint or varnish the 1" x 2" now. (Note the right angle is fastened to the 2" x 8" with screws from inside.)
4. Fasten the plywood triangles in place with screws through pre-drilled holes. Don't forget the small piece of 1" x 2" that joins the tips of the triangle.
5. Sand and complete paint or varnishing the piece.

Picture Frame House

- 1 Floor 3/4" x 2" x 6"
- 1 Back 1/2" x 6" x 9 1/2"
- 1 Rooftop 1/4" x 2 1/2" x 5 3/4"
- 1 Rooftop 1/4" x 2 1/2" x 6"
- Cut popsicle sticks for fence
- 1/4" x 1/4" sticks for picture frame

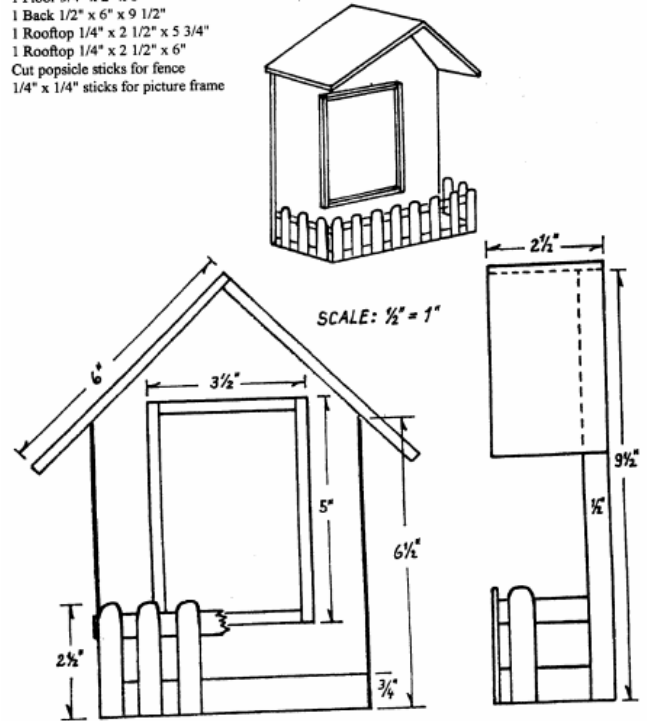

Southern NJ Council

Leather Eyeglass Case
Baltimore Area Council

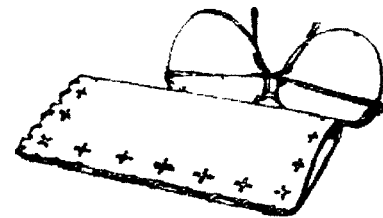

Measure eyeglasses and cut leather (a piece approximately 6" x 6") so glasses fit easily when case is folded. Fold leather and punch holes for lacing using the running stitch. Cut simple design into head of a large nail with a file; then file off nail point. Dampen leather and use small hammer to tap the design on.

Wooden Trivet

Baltimore Area Council

Materials:

- 1 dowel, 4' long, 1" diameter for each Webelos
- Table saw, Sandpaper, Waxed paper, Carpenter's glue
- Felt (approx. 6" X 6")

Prior to the meeting - Cut the dowel into slices about 1 1/4" thick, using the table saw. You will need 37 pieces for each Webelos.

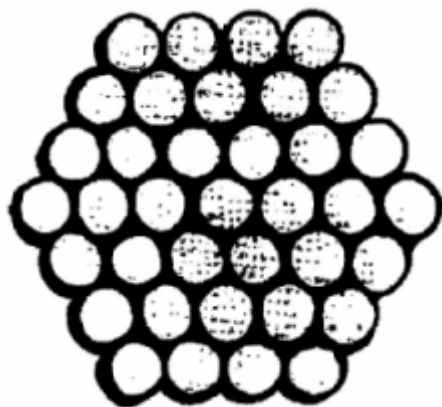
**Have the Webelos -**

1. Sand any rough edges.
2. Lay a piece of waxed paper on the working surface. It can be easily removed from the trivet after the glue has dried.
3. Begin gluing the slices together as shown in the picture.
4. When glue has dried, pull away waxed paper and cut the felt piece to fit the back of the trivet.
5. Glue felt in place.

SCIENTIST TECHNOLOGY GROUP

Baltimore Area Council

A scientist studies things to learn how they behave and why. Scientists try to find out the laws of nature about the things they study. People can use these rules or laws in making things. While working on this activity badge, you will learn a few of the main ideas in physics. Physics is a science with several branches. One of these branches will be weather. You can learn a little about weather in these activity badge requirements. Another branch of physics is called optics. You will have a chance to learn something about sight and find out how your eyes work. Scientists learn a lot by experimenting or trying things out. Try things for yourself. Scientists take nothing for granted. They may be sure an idea is true, but they always test it, if possible, to make certain they are right.

Speakers:

Lab Technician	Researcher	Zoologist
Optometrist	Ophthalmologist	Nuclear Physicist
Weather Forecaster	Nurse	X-Ray Technician
	Science Teacher	

Pack Meeting

- ✓ Honor your Pack leaders by making up some "Scientific Awards." Cut them out of poster board. For example:
 - Gravity is a heavy subject. (Shape of the Earth)
 - Stars are night lights that don't run up bills. (Stars)
 - Astronomers are far-sighted. (Glasses with big eyeballs)
 - Chemists really, stir things up! (Beaker with bubbling mix.)

- ✓ Science Fair: Set up and hold a science fair during your Pack meeting. Show some of the simple experiments you have been doing in your Den meetings.
- ✓ Display items that you have made.

Den Activities

- ✓ Talk about the various branches of science and how they differ.
- ✓ Do the atmospheric pressure tests or balance tests in the Webelos Book.
- ✓ Make Fog.
- ✓ Make Crystals.
- ✓ Do the inertia experiments in the Webelos Book.
- ✓ Visit an eye specialist and learn how the eyes converge and find out what the various eye tests measure
- ✓ Invite a local weatherman to your Den meeting to talk about the climate during the year. How is weather different in
 - ✓ the Southern Hemisphere?
- ✓ Have a slow-motion bicycle riding contest to illustrate balancing skills.
- ✓ Plan a scientific experiment to be demonstrated at the Pack meeting.

Field Trips

- ✓ Visit an eye specialist and learn how the eyes work.
- ✓ Visit the control tower of the Metropolitan Airport or visit a Municipal Airport.
- ✓ Learn about the principles of flight for an airplane and look at all the control dials.

INERTIA

Southern NJ Council

Inertia is the tendency of a thing at rest to remain at rest and a thing in motion to continue in the same straight line. Get a small stick about 10-inches in length and the diameter of a pencil. Fold a newspaper and place it near the edge of a table. Place the stick under the newspaper on the table and let about half the stick extend over the edge of the table. Strike the stick sharply with another stick. Inertia should cause the stick on the table to break into two parts.

PASCAL'S LAW

Southern NJ Council

Materials:

Rubber balloon
Several pins with large heads
Roll of plastic tape

Inflate the balloon and affix little squares of plastic tape to it. Stick each pin through the center of the tape and to their amazement, the balloon will not burst. When you remove the pins, the balloon still will not burst.

What happens: The adhesive substance on the tape acts like a self healing automobile tire, adhering to the pin as it is pressed inward. When the pin is removed, the adhesive is forced outward by the air pressure from within the balloon, atomically sealing the tiny pinholes.

MYSTIC MATCHES

Southern NJ Council

Put several matches in a bowl almost full of water, making a shape like a star.

Stick a pin into a small piece of soap.

Gently dip the soap into the water at the center of the star of matches, taking care not to disturb them. The matches will all move away from the soap.

What happens: When you dip the soap in the water a little of the soap dissolves. The surface tension of the clean water is stronger than that of soapy water, so the clean water around them pulls the matches outward.

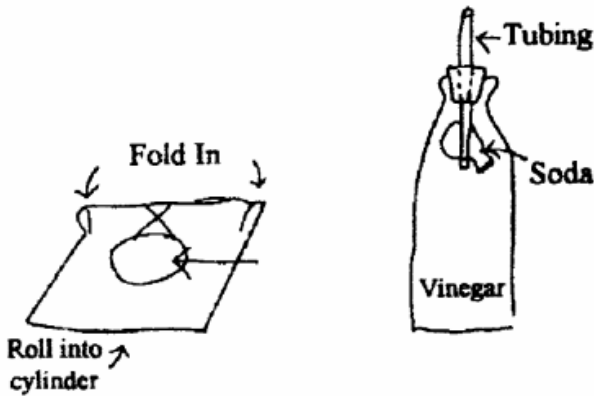

MAKE A FIRE EXTINGUISHER

Southern NJ Council

Materials: 1 or 2 quart bottle with stopper to fit 3" of 1/2" glass, metal or plastic tubing (Tube from an old Windex bottle can be used)
Spoonful of baking soda
Vinegar
Facial tissue

1. Drill hole in stopper and insert tubing
2. Wrap soda in tissue and attach tissue to tube with rubber band
3. Fill bottle one half full of 1 part vinegar and 1 part water
4. Insert stopper in bottle with soda inside bottle, but not touching vinegar solution
5. To operate, tip bottle upside down, soaking the tissue paper with vinegar

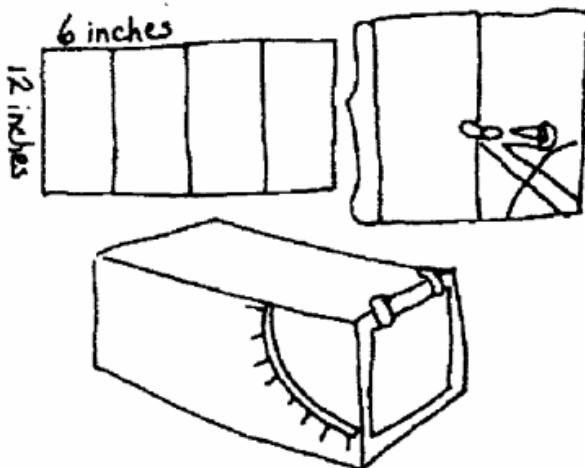

RECORD WIND SPEED

Southern NJ Council

To see how fast or slow the wind blows, make an anemometer (a wind speed measurer)

You will need - stiff cardboard 24" x 12"

1. Measure four 6" widths with a ruler, and draw pencil lines with scissors.
2. Set a compass to 4" and draw an arc on the cardboard as shown.
3. Cut out a narrow slot along the arc.
4. Mark numbers at equal intervals along the slot.
5. Fold the cardboard inward along the scored lines.
6. Put cellophane tape along the two edges and along all the folded edges.
7. Cut a piece of paper 4 3/4" square and tape it to the end of the box as shown. Take the anemometer outside and point the flap toward the wind. Each night and morning, record the level that the flap reaches

BOILING ICE

Southern NJ Council

In a heatproof jar with lid, boil a half-inch of water with the lid on loosely so some of the steam can escape. Then tighten the lid and turn jar over. Put an ice cube or two on the jar bottom. In a moment the water will boil again.

What happens? The air pressure has been reduced in the jar by the ice condensing the water vapor inside. The boiling point of a liquid depends on atmospheric pressure.

BALLOON AND CAN RACE

Southern NJ Council

Each team will need a balloon for every Webelos and a fruit can for each team. Each team will have a chair on each end of the room. Each team is divided with half of the team behind each of that teams chairs. The can is placed on a chair.

One boy holds the balloon in the can and blows it up enough to make the can stick on around the balloon. He then carries the balloon, with the can hanging on, to the other chair. He then deflates his balloon and the next boy inflates his own balloon and carries it and the can back to the original chair. The first team to switch locates wins.

EXPERIMENTS IN AIR PRESSURE

Baltimore Area Council



Shooting Back

Place an empty soda bottle on its side. Put a wad of paper in the neck and try to blow it in. It comes back out.

Why? When you blow into an enclosed space like a bottle, you increase the air pressure inside. Since pressure will equalize when it can, the air rushes out of the bottle, taking the wad of paper with it.

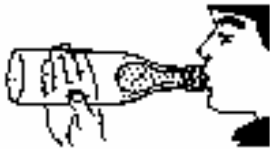

Balloon in Bottle –

Place a deflated balloon inside a two-liter bottle, with the lip of the balloon over the top of the bottle. "Cry to blow up the balloon.

What happens? Air pressure inside the bottle increases as the balloon takes up space, so air pressure is fighting against you. To inflate the balloon, you would need to compress the air trapped between the balloon and the bottle. To compress air requires force. The human lungs are not strong enough to inflate the balloon and to compress the trapped air.

Making Air Work for Us

Use a balloon to pick up a glass -- Place a deflated balloon in a glass. Blow up the balloon until it is tight around the edge of the glass. Hold the end of the balloon shut and pick up the glass.

Use a balloon to lift books -- Place a deflated balloon under



a stack of books. As you blow the balloon up, the books will rise. A hydraulic lift is based on this principle.

EXPERIMENTS IN ATMOSPHERIC PRESSURE

Baltimore Area Council

We live under a blanket of air called the earth's atmosphere. The air in the atmosphere exerts pressure of almost fifteen pounds per inch on every surface on earth.

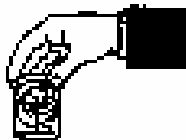

Diving Bell

Place a piece of crumpled paper in the bottom of a glass or tin can. Turn the glass upside down and submerge it in a bucket of water. The paper will remain dry. Why? The air, which filled the "empty" space in the glass, stopped the water from entering.



Hanging Water

Fill a glass to overflowing and lay a piece of cardboard atop it. Support the card with one hand, turn the glass upside down, and remove your hand from the card. The card does not fall. It remains on the glass and allows no water to escape. Why? The air pressure from below the cardboard is

greater than the pressure of the water above and presses the card tightly against the glass.

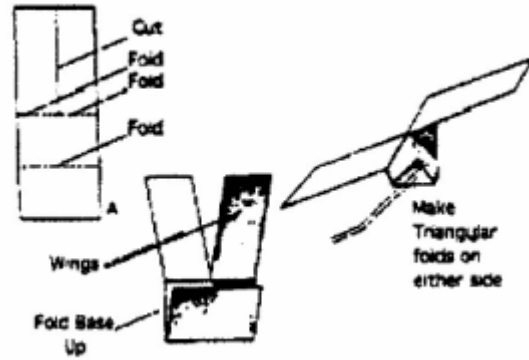

Wedged Glasses

Place two glasses together with a piece of wet construction paper between them. Burn a candle in the bottom glass. The glasses become "welded" together. Why? The flame uses up the oxygen in the bottom glass, so the pressure is now lower in this glass.

Auto Gyro

Baltimore Area Council

Materials: Paper 3 1/2" wide by 8 1/4" long

The principle of the Auto Gyro can be easily demonstrated by making one as shown in the sketch.

1. Using a piece of paper 3 1/2" wide by 8 1/4" long, cut down the center of the paper 4" and then fold the cut sections to opposite sides as shown, to form the two wings.
2. Fold the balance in half; and then make two triangular folds to the midline and your Auto Gyro is ready.
3. Make two other Auto Gyros basically the same as the first one, but shorten the wing length from four inches to three inches on the second one and to two inches on the third one.

Try flying from the same height and observe how each model reacts. Does any thing seem to slow their descent? What actually makes it spin? Note the order in which the three models reached the ground. Are wing size, air resistance, and rate of descent related?

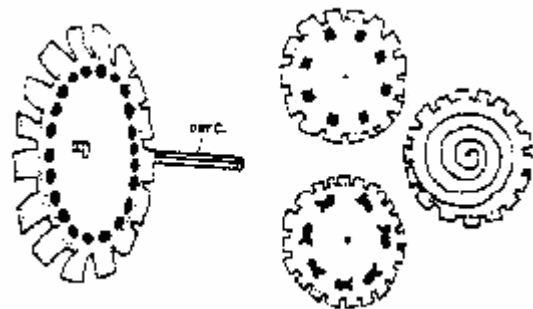

Spinner Scope

Baltimore Area Council

Materials: Paper plates, scissors, watercolor markers, pushpin, unsharpened pencil with eraser top

1. Cut out notches around edge of plates as shown.

2. Draw a design on each plate with markers. Draw a spiral, small circles close to each other, or a simple object, such as a fish.
3. Poke a pushpin through center of plate, then into eraser end of pencil.
4. Stand in front of mirror. Spin pencil between hands as you peer through the notches. Each design will produce a different optical illusion as the spinning elements appear to merge.

POW WOW EXTRAVAGANZAS

Southern NJ Council

Catch a Dream

January 22, 2005

Lakeside School, Millville, NJ

Call Southern NJ Council, 856-327-1700, extension 32, or visit the website, www.snjscouting.org for more information

Bucks County Council

Putting the Fun into Your Pack

November 6, 2004

Bux-Mont Christian Church, Ivyland, PA

Call Bucks County Council, 215-3487205, or visit the website, <http://www.buckscountybsa.org/> or E-mail mw0001@mas.com for more information

Hudson Valley Council

Still Having Fun

Presented by Pow and Wow (Cindy & Keith)

November 13, 2004

Sanford, NC

Call the Pow Wow Info line at 845-430-2727, or visit the website, www.hvusc.org, for more information. Cindy, the

Pow Wow Chair has promised to tell me as soon as the school confirms the date. *I attended this Pow Wow last year and had a great time. I met people from several other councils who shared my opinion that it is one of the best!!*

Oconeechee Council

Theme (Later)

November 13, 2004

Sanford, NC

Call Oconeechee Council, 800-662-7102, or visit the website, <http://www.oconeechee.org> for more information. Gary, the Pow Wow Chair has promised to keep informed as theme and other details are finalized.

Indian Waters Council, BSA

"Set Sail for Adventure" University of Scouting

January 22, 2005

Swearingen Engineering Center, USC, Columbia, SC

Call Indian Waters Council, 803-750-9868 or visit the website, www.universityofscoutingiwc.com or E-mail, universityofscouting@msn.com for more information

Circle Ten Council

Diamond Anniversary of Cub Scouting

October 30, 2004

Lakeview High School, Garland, TX

Gee, last year it was at Creekview. I guess it's bigger this year - a lake is bigger than a creek ☺☺ CD

Call Circle Ten Council, 408-280-5088, or visit their website, www.circle10.org, or

http://www.geocities.com/wes_mays/PowWow/index.htm for more information.

Northern NJ Council

Tools, Tips and Training

November 20, 2004

Cedar Grove High School, Cedar Grove, NJ

Call Northern NJ Council, 973-589-8002, E-mail powwow@njbsa.org or visit the website, <http://www.njbsa.org> for more information

Ouachita Area Council

Cruising BSA

November 6, 2004

Westminster Presbyterian Church, Hot Springs, AR

Call Ouachita Area Council, 501-623-6601 or visit the website, www.ouachitabsa.org for more information

Mid-Iowa Council

Cubs Just Wanna Have Fun

November 6, 2004

Valley South Woods Freshman High School, West Des Moines, IA

Call Mid Iowa Council, 800-999-SCOUT or visit the website, www.bsa-ia.org for more information

WEB SITES

Connecticut Rivers Council

Have a New Den Leader??

Go to Northern NJ Council's Web Site, www.njbsa.org/ and click on the Den Leader's Patch. They loaded most of the material from the new "New Den Leader's Kit" onto their site. Plus provided some other useful links. Check it out!!

And then next you need lots of friends with great ideas and some of the best are on the Internet. We hope you enjoy these fun web sites.

<http://www.wtsmith.com/rt.html> - Bill Smith's Unofficial Roundtable One of the best... Great collection of Scouting Documents. What we used to call BIN items.

<http://www.scoutingthenet.com> A great cross reference of many Scout sources. It is operated from Arkansas!!

<http://www.cub-roundtable.com/>

<http://www.usscouts.org/usscouts/advance/cubscout/intro.html> One of the great parts of www.usscouts.org. Learn all about Cub Scout Advancement here

<http://www.macscouter.com> A great collection of Pow Wow books plus many songs and ceremonies and more.

<http://www.kidsdomain.com/> - great for crafts

<http://www.funschool.com/> kids activities, movies & stories

<http://www.safetypub.com> children's fire prevention

handbook and other publications

<http://www.redhotdots.net> tells about children's safety

<http://www.redcross.org> - home page of the American Red

cross